

USER MANUAL

MODEL:

KDS-17EN-SW2

**2x1 4K60 4:4:4 AVoIP Switcher Encoder
with Dante**



Contents

Contents	2
Introduction	3
Getting Started	3
Overview	4
Typical Applications	5
Controlling your KDS-17 device	5
Defining KDS-17EN-SW2	6
Mounting the KDS-17 Devices	8
Connecting the KDS-17 Devices	10
Configuring the Network Switch	11
Installing the Kramer recommended SFP transceiver	12
Connecting the Audio/Input Output	12
Connecting to a KDS-17 device with RS-232	13
Operating and Controlling KDS-17 Devices	14
Using the LCD Display	14
Operating via Ethernet	16
Using the KDS-17EN-SW2 Embedded Web Pages	19
Dashboard: Overview of Streaming	20
AV Settings: Define Video and Audio Output	22
EDID: Setting Display Metadata	25
Device Settings: General, Network, Time & Date	26
Security: Passwords, HTTPS, 802.1X and AES256	31
Gateway: CEC, RS-232 and IR definitions	36
Diagnostics: Status, Connections and Logging	39
About	41
Upgrading Firmware	42
Defining Dante or AES67 Audio as an Audio Source or Destination	43
Defining Dante input to the KDS-17EN-SW2 encoder	43
Using Audinate Dante Software	43
Technical Specifications	46
Protocol 3000	48
Understanding Protocol 3000	48
Protocol 3000 Commands	49
Result and Error Codes	60

Introduction

Welcome to Kramer Electronics! Since 1981, Kramer Electronics has been providing a world of unique, creative, and affordable solutions to the vast range of problems that confront the video, audio, presentation, and broadcasting professional on a daily basis. In recent years, we have redesigned and upgraded most of our line, making the best even better!.

Getting Started

We recommend that you:

- Unpack the equipment carefully and save the original box and packaging materials for possible future shipment.
- Review the contents of this user manual.



Go to <https://www.kramerav.com/downloads/kds-17en-sw2> to check for up-to-date user manuals, application programs, and to check if firmware upgrades are available (where appropriate).

Achieving Best Performance

- Use only good quality connection cables (we recommend Kramer high-performance, high resolution cables) to avoid interference, deterioration in signal quality due to poor matching, and elevated noise levels (often associated with low quality cables).
- Do not secure the cables in tight bundles or roll the slack into tight coils.
- Avoid interference from neighboring electrical appliances that may adversely influence signal quality.
- Position your Kramer KDS-17EN-SW2 away from moisture, excessive sunlight and dust.

Safety Instructions

Caution:

- This equipment is to be used only inside a building. It may only be connected to other equipment that is installed inside a building.



- For products with relay terminals and GPIO ports, please refer to the permitted rating for an external connection, located next to the terminal or in the User Manual.
- There are no operator serviceable parts inside the unit.

Warning:

- If using a power cord, only use the Kramer approved power cord.

Recycling Kramer Products

The Waste Electrical and Electronic Equipment (WEEE) Directive 2002/96/EC aims to reduce the amount of WEEE sent for disposal to landfill or incineration by requiring it to be collected and recycled. To comply with the WEEE Directive, Kramer Electronics has made arrangements with the European Advanced Recycling Network (EARN) and will cover any costs of treatment, recycling and recovery of waste Kramer Electronics branded equipment on arrival at the EARN facility. For details of Kramer's recycling arrangements in your particular country go to our recycling pages at www.kramerav.com/quality/environment.

Overview

Congratulations on purchasing your Kramer KDS-17EN-SW2 2x1 4K60 4:4:4 AVoIP Switcher Encoder with Dante.

KDS-17 advanced encoder/decoders stream 4K video signals via Ethernet over copper cable in unicast (one-to-one) or multicast (one-to-many) configurations. Supports audio Dante, USB, IR, RS-232 or CEC signals.

KDS-17EN-SW2 provides:

- High quality video and audio streaming
- Outstanding end-user experience
- Ideal for large-scale deployments
- Simple planning and rollout

Outstanding end-user experience

Present video in superb 4K60 4:4:4 resolution, with best-in-class digital audio. With KDS-17, every visual detail and every nuance of sound comes through super-clearly. Enjoy extensive control of video walls, advanced connectivity options, and a wide choice of inputs/outputs and settings options.

Ideal for large-scale deployments

Provide a high-performance solution fine tuned to the needs of large enterprise, education and government sites, with integrated advanced management capabilities and support for many simultaneous video streams.

Easy planning and deployment

Easily and confidently integrate the AV solution into any IP network. Create A/V-enabled spaces of varying sizes swiftly and effortlessly, even without prior AV expertise. KDS-17 is very bandwidth-efficient, allowing you to leverage your IT infrastructure without perceptible network performance disruptions. Use of the existing IT network and Ethernet cabling, simplified switch configurations, and reduced dependence on skilled technicians save deployment time and cost.

Typical Applications

KDS-17EN-SW2 is ideal for the following typical applications:

- Real-time essential installations such as command and control rooms.
- Large scale AV content sharing installations using existing wires and infrastructure in corporate offices and government applications.
- AV distribution systems with one or more sources and multiple displays in schools, universities, and public venues.
- AV installations where low latency KM/KVM capabilities are required.

Controlling your KDS-17 device

Control your KDS-17 device directly via Navigation buttons, or via:

- The Ethernet using built-in user-friendly web pages.
- Protocol commands.
- Panta Rhei AVoIP

Defining KDS-17EN-SW2

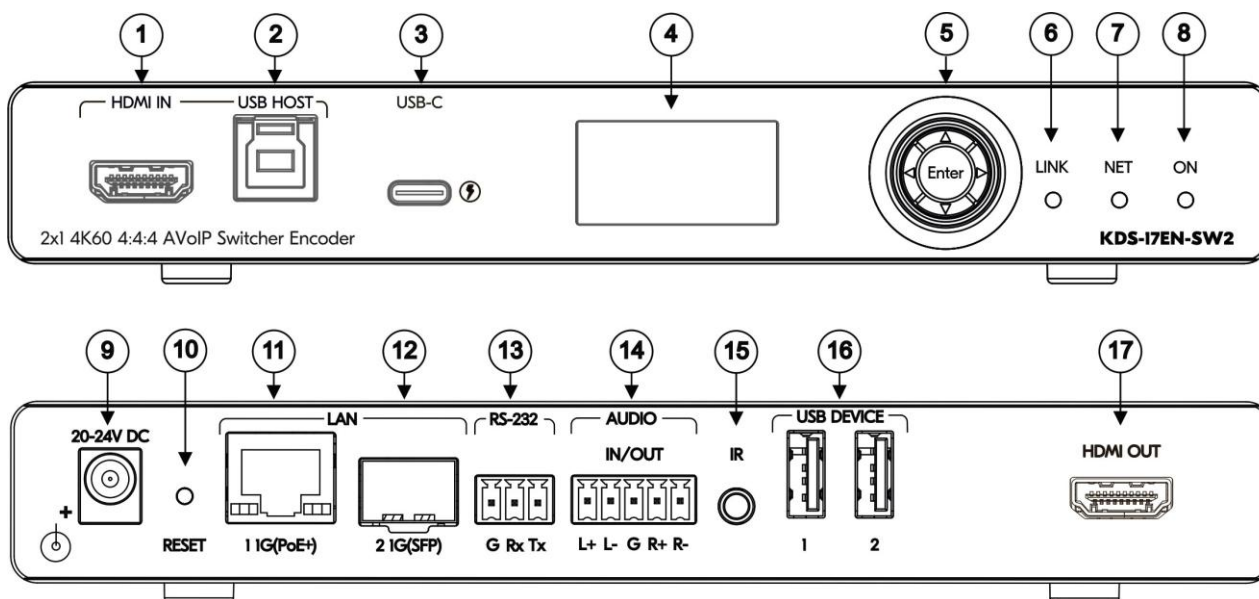

#	Feature	Function
1	HDMI IN Connector	Connect to an HDMI source.
2	HOST USB Type B Port	Connect to a USB host, for example, a PC for KVM/USB support.
3	HOST USB Type C Port	<p>Connect to a USB-C host (for example, a room PC) to communicate with the USB devices (for example, a PTZ camera) that are connected to the USB device ports, to transmit audio and video signals and connect to the LAN.</p> <p>Charges connected hosts that support USB Power Delivery 2.0, up to 60W, when the device is powered by the optional PS-2006 20V DC power adapter.</p> <p>After connecting or disconnecting a USB-C connection, wait 3 seconds for unit stabilization.</p>
4	LCD Display	Use for device configuration such as unique channel/AV stream setting.
5	Menu Navigation Button	◀ Press to return to the previous menu.
		▶ Press to go to the next menu.
		▲ Press to move up to the next configuration parameter.
		▼ Press to move down to the next configuration parameter.
		Enter Press to enter the menu and to accept changes.
6	LINK LED	Lights Green A link is established from KDS-17EN-SW2 to KDS-17DEC and is transmitting A/V.
		Flashes Green HDMI or USB-C input is detected, but no valid AV signal is detected.
		Off No HDMI or USB-C input is detected.

#	Feature	Function	
7	NET LED	Off	No IP address is acquired.
		Lights Green	A valid IP address has been acquired.
		Flashes Green Very Fast	When a device identification command is received (Find me), it flashes for 60 seconds.
		Lights Yellow	No DHCP found, device falls back to IP address in the subnet range 192.168.0.0/16.
		Lights Red	Security is blocking IP access.
8	ON LED	Lights Green	Device power is on.
		Lights Green Fast	Firmware is downloaded in the background.
		Flashes Green Very Fast	A device identification command is sent (Flag me), and flashes for 60 seconds.
		Lights Yellow	Device falls back to the default IP address (192.168.1.39).
		Lights Red	Security is blocking IP access.
		Flashes Red	On fallback address acquiring, flashes continuously in a slow 0.5/10sec cadence.
9	20-24V DC Connector	Connect the optional 20-24V DC power adapter (purchased separately). The optional charger PS-2006 is necessary, if USB-C charging is required.	
10	RESET Recessed Button	Press and hold for 10 seconds to reset the device to factory default values. All LEDs flash.	
11	LAN 1: 1G(PoE+) RJ-45 Port	Connect to the LAN. KDS 17EN-SW2 is powered by PoE+ (power over Ethernet) delivered through the LAN PoE+ port, unless the optional 20-24V DC power adapter is attached. Unicast: Connect for streaming either directly to a decoder or via LAN. Multicast: Connect to multiple decoders.	
12	LAN 2: SFP OUT IN Connector	Plug in an SFP (Small Form Factor Pluggable) optical or copper transceiver for streaming over cable.	
13	RS-232 3-pin Terminal Block Connector	Connect to an RS-232 device to use as a Gateway and bi-directional signal extension (even when no AV signal is extended).	
14	AUDIO IN/OUT 5-pin Terminal Block Connector	Connect to a balanced analog stereo audio source/acceptor.	
15	IR 3.5 Mini Jack	Connect to an IR sensor or emitter for bi-directional signal extension (even when no AV signal is extended). Expected voltage for IR receiver - (3.3V).	
16	USB Type A Charging Ports (1 and 2)	Connect to USB devices, for example, to a speakerphone and webcam.	
17	HDMI OUT Connector	Connect to loop the signal.	

Mounting the KDS-17 Devices

Before installing the devices, verify that the environment is within the recommended range:



- Operation temperature – 0° to 40°C (32 to 104°F).
- Storage temperature – -40° to +70°C (-40 to +158°F).
- Humidity – 10% to 90%, RHL non-condensing.

Caution:

- Mount KDS-17EN-SW2 before connecting any cables or power.

Warning:



- Ensure that the environment (e.g., maximum ambient temperature & air flow) is compatible for the device.
- Avoid uneven mechanical loading.
- Appropriate consideration of equipment nameplate ratings should be used for avoiding overloading of the circuits.
- Reliable earthing of rack-mounted equipment should be maintained.
- Maximum mounting height for the device is 2 meters.

Mount KDS-17EN-SW2 in a rack:

- Use the recommended rack adapter (see www.kramerav.com/product/KDS-17EN-SW2)

1. Unfasten the knobs to remove the open panel.

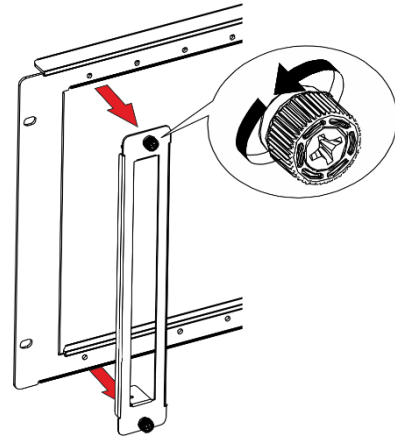

2. Slide the device into the panel opening.

3. Attach the device to the panel using 4 screws (2 on each side to secure the device to the panel).

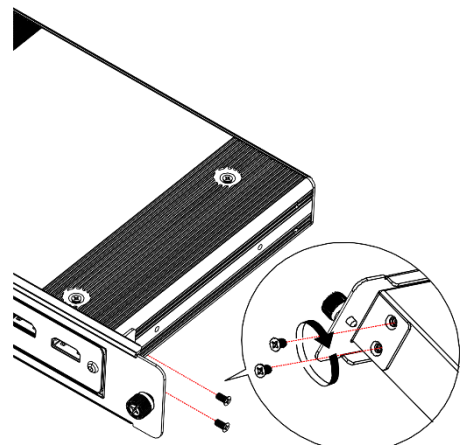

4. Slide the open panel with the device into the rack opening.

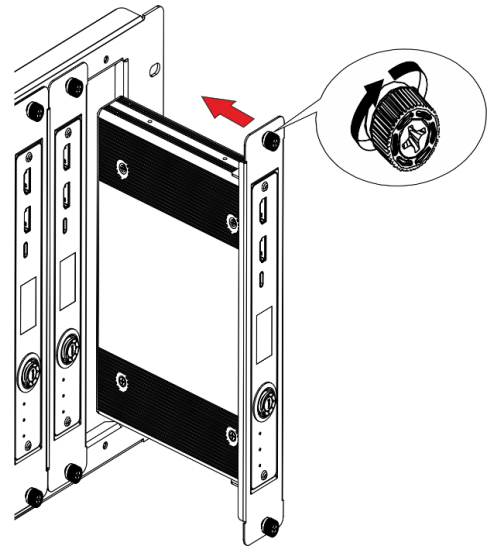

5. Turn the knob to secure panel to rack.

Mount the on a surface using one of the following methods:

- Attach the rubber feet and place the unit on a flat surface.
- Fasten a bracket (included) on each side of the unit and attach it to a flat surface.

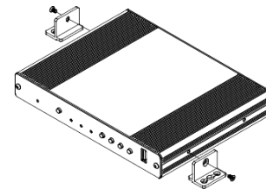

For more information go to www.kramerav.com/downloads/kds-17en-sw2

Connecting the KDS-17 Devices



By-default, KDS-17 devices use PoE+ for power. To connect the product to mains electricity, an optional power adapter (PS-2006) can be purchased. Charging from the USB type C port requires the power adapter.

Always switch off the power to a device before connecting it to KDS-17EN-SW2. After connecting your devices, connect their power and then switch on the power to each device.

KDS-17EN-SW2

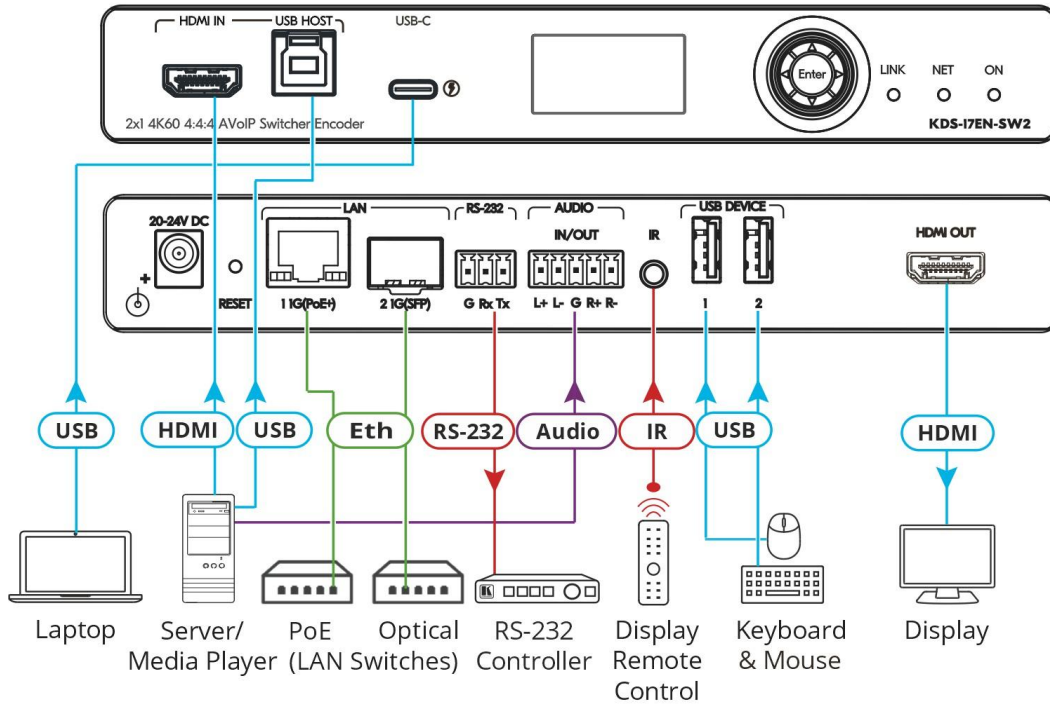

KDS-17DEC

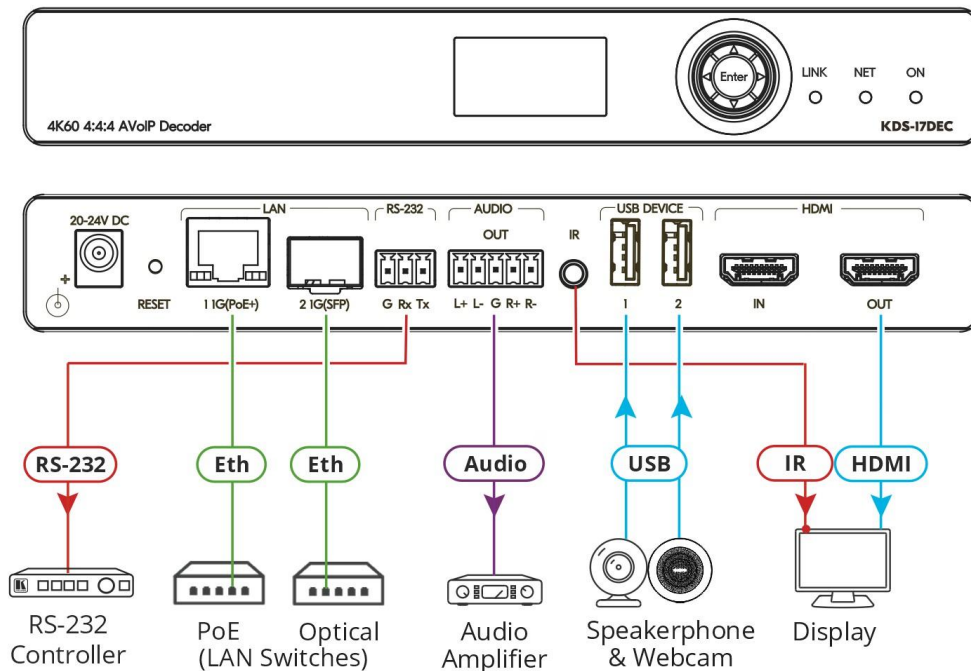

To connect KDS-17EN-SW2 as illustrated in the example in Figure 3:

1. Connect an HDMI source (for example, a server or a media player) to the HDMI IN connector on the KDS-17EN-SW2.
2. Connect a balanced stereo audio source (for example, the server audio connector) to the AUDIO IN/OUT 5-pin terminal block connector on the KDS-17EN-SW2.
3. Connect the LAN MEDIA 1G(PoE) RJ-45 port on the KDS-17EN-SW2 to the LAN MEDIA 1G (PoE) RJ-45 port on the KDS 17DEC via a LAN switch.
4. Connect the HDMI OUT connector on the KDS-17EN-SW2 to an HDMI acceptor (for example, a display).
5. Connect the AUDIO OUT 5-pin terminal block connector on the KDS 17DEC to a balanced stereo audio acceptor (for example, an audio amplifier).
6. Connect the USB ports:
 - On KDS-17EN-SW2, connect a laptop or media center to the USB HOST port or to the USB-C port. After connecting a USB-C connection, wait 3 seconds for unit stabilization.
 - On KDS 17DEC, connect a mouse and a keyboard to the two USB type A ports .
7. Control the display connected to KDS 17DEC from the encoder side via IR:
 - On KDS-17EN-SW2, connect an IR sensor cable to the IR 3.5mm mini jack .
 - On KDS 17DEC, connect the IR 3.5mm mini jack to an emitter cable and attach the emitter side to the IR sensor of the display.
8. Connect RS-232 3-pin terminal block connectors:
 - On the KDS-17EN-SW2, connect the RS-232 port to a laptop/controller.
 - On the KDS 17DEC, connect RS-232 to the display.



RS-232 bidirectional signals can be sent between the display and the laptop connected to the HDMI OUT connector on the KDS 17DEC.

Configuring the Network Switch

Before setting the system, make sure that your AV over IP network switch meets the following minimum requirements:

- IGMP Snooping – On.
- IGMP Querier – On.
- IGMP Immediate/Fast Leave – On.
- Unregistered Multicast Filtering – On.
- Jumbo frames – Enable (when AES256 full encryption is required).

Installing the Kramer recommended SFP transceiver

To install the SFP MM/SFP SM Kramer recommended transceiver:

1. Pull the bail out and remove the currently installed transceiver, insert the protective cap and store in a safe place.
2. Make sure the bail of the new transceiver is pushed up, in the closed position.
3. Insert the new transceiver into the relevant optical device SFP slot and push it in until it clicks.
4. Remove the protective cap and store it in a safe place for future use.

Warning: Connecting the SFP connector to an LC(APC) fiber connector may cause poor performance and damage the connector!

Warning: Class 1 Laser Product

- Invisible laser radiation present on present.
- Avoid long-term viewing of laser.
- Avoid the use of magnifying viewing aids or instruments (such as binoculars, telescopes, microscopes and magnifying lenses, but not spectacles or contact lenses).
- Avoid placing optical devices in the emitted beam that could cause the concentration of the laser radiation to be increased.

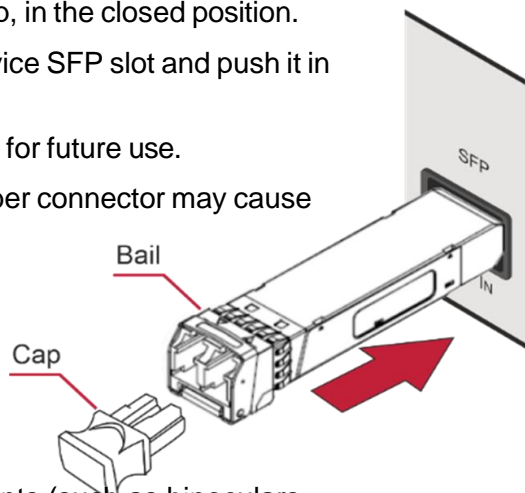

To achieve specified extension distances, use the recommended Kramer cables available at www.kramerav.com/product/kds-en17-sw2 Using third-party cables may cause damage!

Connecting the Audio/Input Output

The following are the pinouts for connecting the input/output to a balanced or unbalanced stereo audio acceptor:

To a balanced stereo audio source/acceptor:



To an unbalanced stereo audio acceptor:

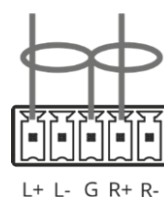

To an unbalanced stereo audio source:



Connecting to a KDS-17 device with RS-232

KDS-17EN-SW2 can transmit or receive data via the RS-232 connection and relay that data to the remote encoder or decoder.

KDS-17 devices feature an RS-232 3-pin terminal block connector which can be used to transmit RS-232 data between the encoder and decoder and to remotely control connected devices.

Connect the RS-232 terminal block on the rear panel of the KDS-17 device to a PC/controller, as follows:

From the RS-232 9 pin D-sub serial port connect:

- Pin 2 to the Tx pin on the KDS-17 RS-232 terminal block
- Pin 3 to the Rx pin on the KDS-17 RS-232 terminal block
- Pin 5 to the G pin on the KDS-17 RS-232 terminal block

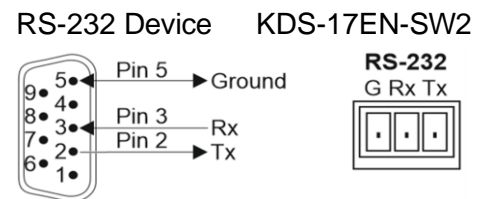

Operating and Controlling KDS-17 Devices

Using the LCD Display

Connect the device's LAN 1 port to a LAN switch with PoE+ (power over ethernet). If PoE is unavailable, connect the device to the 20-24V DC power adapter and connect the adapter to the mains electricity. The LEDs light white while the device boots and then the ON and NET LEDs light green or yellow, indicating that the device is on and has a valid IP address.

Using the Menu Navigation button

Use the menu navigation button to view and change device parameters in the LCD display.

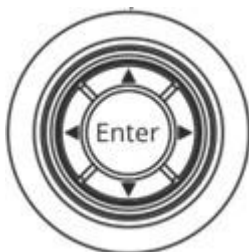

- **Up/down** arrows – Move to the previous/next menu item.
- **Left/right** arrow – Open the previous/next level menu.
- **Enter** button – Select a menu option / accept and save changes.
If the LCD display is blank a single press of Enter will cause it to display the connected channel number, a second press of Enter opens the Main Menu.

Use Enter to accept and save changes in the MAIN MENU > DEV SETTINGS.

Using the KDS-17EN-SW2 LCD Display Menu

To access the LCD display menu, press Enter on the Menu Navigation button: The Main Menu is displayed.

The **Main Menu** has 3 sub-menus (listed below):

- An asterisk (*) indicates the active option.
- **Changes are made in MAIN MENU > DEV SETTINGS.** Press Enter on an option to make it active.

Main Menu Item	Sub-menu options	Output
1. DEV STATUS	CONTROL STAT	The IP address, subnet mask and gateway address used for streamed P3K API, RS-232 and IR data.
	STREAM STAT	The IP address, subnet mask and gateway address used for streamed AV content.
	DANTE STAT	The IP address, subnet mask and gateway address used for streamed DANTE or AES67 digital audio.
	INPUT STATUS	<ul style="list-style-type: none"> - I/O Resolution if a signal is input or output. - HDCP status of the input/output.
	TEMPERATURE	Device temperature.
2. DEV INFO	FW	Firmware version.
	BL	Bootloader version.
	HW	Hardware version.
3. DEV SETTINGS Use this option to change settings.	INPUT	Select the source of the AV input: HDMI IN or USB_C IN .
	EDID	Select the source of the EDID for the HDMI IN and USB-C ports from: <ul style="list-style-type: none"> - DEFAULT - Use the encoder's built-in EDID - CUSTOM - Use a custom EDID uploaded in the embedded web pages. - REMOTE - Copy the EDID of the display attached to the remote decoder.
	HDCP	ON or OFF . Enables/disables HDCP encryption of the output.
	CH DEFINE	Channel ID of the output stream. To change the channel use the up/down arrows to change each digit, press Enter to confirm the final number (this option is not available on devices provisioned by the Panta Rhei AVoIP Manager).
	RESET IP	Enable/disable DHCP. <ul style="list-style-type: none"> - If DHCP is enabled, the device will prompt you to save and reboot. - IF DHCP is disabled, the default IP is shown and can be edited using the arrow keys to select digits.

Operating via Ethernet

Allocating an IP Address to the Device

By default, DHCP is enabled, and assigns an IP address to the devices. If a DHCP Server is not available, for example, if LAN 1 is connected directly to a laptop, the device will try to allocate the default IP address of 192.168.1.39 (encoder) or 192.168.1.40 (decoder).

If the default IP address is unavailable, the system searches for a random unique IP in the range of 192.168.X.Y. The allocated IP address can be viewed in the LCD Display.



If both these options fail, then follow the instructions in [Connecting Ethernet Port Directly to a PC on the next page](#).

To view the allocated IP address on the LCD Display

1. Connect **LAN 1** to a LAN switch with PoE+ (power over ethernet). The LEDs light white while the device boots and then the ON and NET LEDs light green or yellow, indicating that the device is on and has a valid IP address.
2. Use the **Menu Navigation** button to view the assigned IP address on the LCD screen:
 - a. Click **Enter** to display the channel number and **Enter** again, to display the LCD's MAIN MENU.
 - b. Use the navigation arrows to select DEV STATUS > LAN1 STATUS and the device IP is displayed.

Setting the Channel Number

Each encoder requires a unique channel number, and the connected decoders must be tuned to the encoder's channel. You can set the channel number via the LCD screen menu or the embedded web pages.

To set the channel number in the LCD Display's menu:

1. Connect **LAN 1** to a LAN switch with PoE+ (power over ethernet). The LEDs light white as the device boots and then the ON and NET LEDs light green or yellow, indicating that the device is on and has a valid IP address.
2. Use the **Menu Navigation** button to set the channel number with the LCD screen: Press Enter to display the channel number and Enter again, to display the LCD's MAIN MENU.
3. Use the arrows to select DEV SETTINGS > CH DEFINE.
4. A cursor will flash under the first digit of the channel number. Use the up/down arrow keys to change the digit and the right arrow to move to the next digit. Press Enter to save your selection.
5. The channel ID must be the same on the decoder.

To set the channel number in the embedded web pages (if not using the LCD Display)

1. Find the device's IP address (see [Allocating an IP Address to the Device above](#)).
2. Enter the IP address in a browser on a computer connected to the same network as the device (or on the computer to which the device is connected).
3. In the Main page (Dashboard tab) set the Channel ID.

Accessing the Embedded Web Pages

The embedded web pages are an HTML user interface stored inside the device.

1. The embedded web pages are accessed by entering the device's IP address in a browser (on a computer) connected to the same network as the device.
2. If you don't know the device's IP address, see [Allocating an IP Address to the Device on the previous page](#).
3. If security is enabled, enter the Password (default admin).

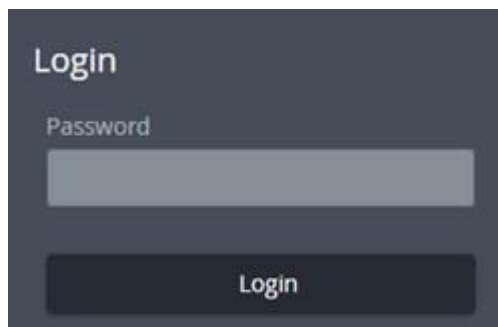

Connecting Ethernet Port Directly to a PC

You can connect the Ethernet port directly to the Ethernet port on your PC using LAN 1 (use a crossover cable with RJ 45 connectors).



This type of connection is recommended for identifying KDS-17EN-SW2 with the factory configured default IP addresses.

After connecting the device to the Ethernet port, configure your PC as follows:

1. Click **Start > Settings > Network and Internet**.
2. Click **Change Adapter Settings**.
3. Highlight the network adapter you want to use to connect to the device and click **Change settings of this connection**.
The **Local Area Connection Properties** window appears (see image on the right).
4. Highlight **Internet Protocol Version 4 (TCP/IPv4)**.

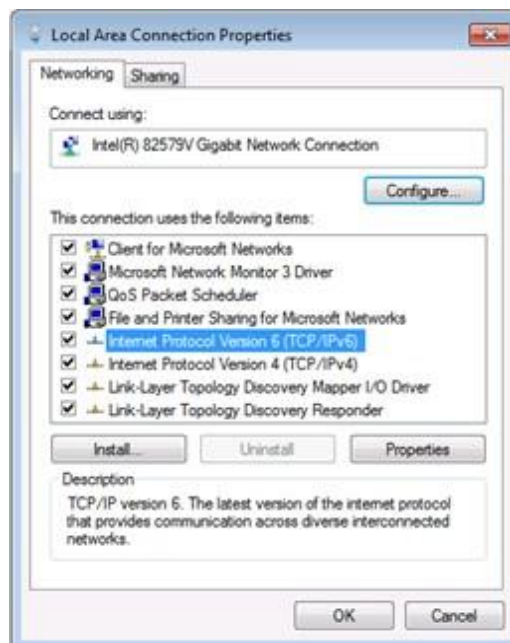

5. Click **Properties**.

The Internet Protocol Properties window appears.

6. Select **Use the following IP Address** for static IP addressing and fill in the details.

You can use any IP address in the range 192.168.1.1 to 192.168.1.255 (excluding 192.168.1.39 and 192.168.1.40) that is provided by your IT department.



6. Click **OK**.

7. Click **Close**.



Connecting the Ethernet Ports

You can connect the Ethernet ports of KDS-17EN-SW2 to the Ethernet port on a network hub/switch (they must both be connected to the same network) or connect them directly to one another using a cable with RJ 45 connectors.

Configuring the Ethernet Port

You can set the Ethernet parameters via the embedded web pages (requires a network hub or switch connection).

Using the KDS-17EN-SW2 Embedded Web Pages

You can also configure KDS-17EN-SW2 via Protocol 3000 commands (see [Protocol 3000 on page 48](#)).



If a web page does not update correctly, clear your Web browser's cache.

Some features might not be available in some mobile device operating systems.

For instructions on how to connect the encoder and load the web pages, see [Accessing the Embedded Web Pages on page 17](#).

To Browse the KDS-17EN-SW2 Web Pages

1. Open your Internet browser.
2. Type the IP number of the device in the Address bar of your browser. For example, the default IP number: The Login window appears.



3. Enter the Password (admin, by default).

The Dashboard page appears.

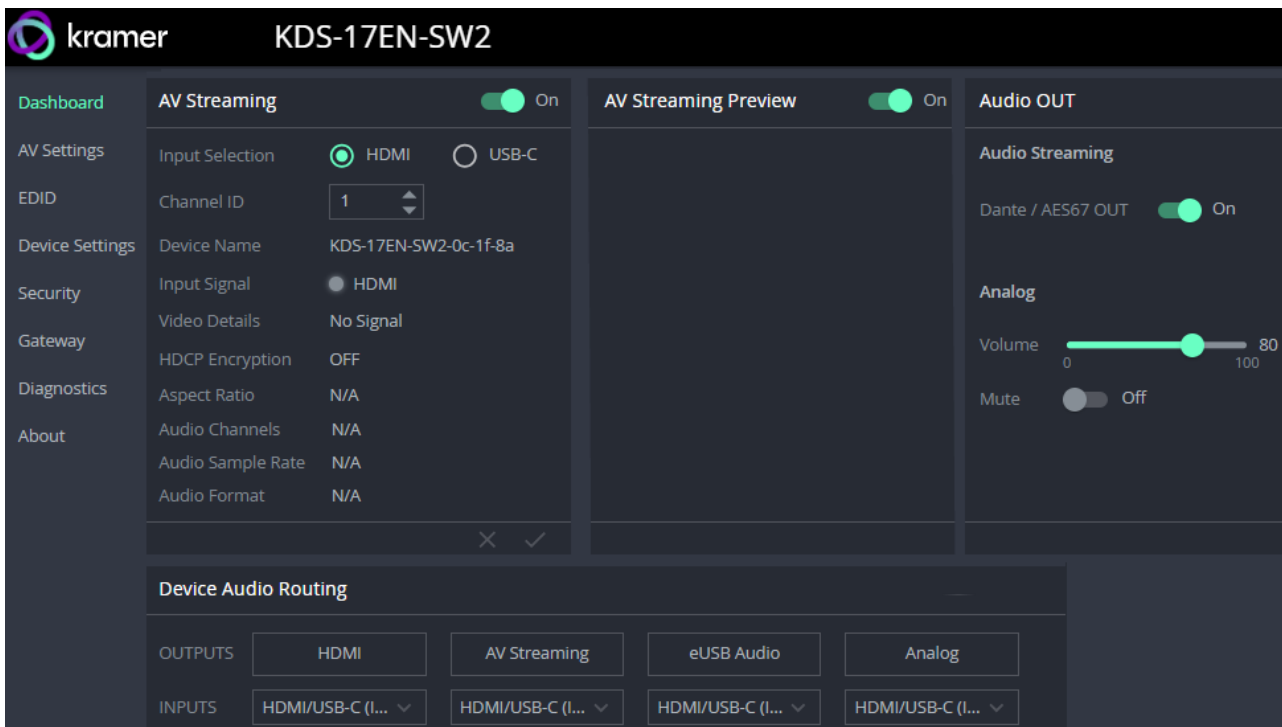
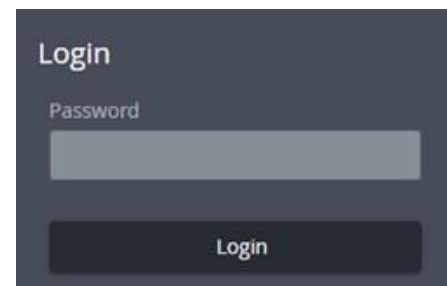

4. Click the tabs on the left side of the screen to access the relevant web page.

Dashboard: Overview of Streaming

The KDS-17EN-SW2 Dashboard shows an overview of AV streaming and audio information. Use the dashboard to set the streaming channel, mode and audio parameters.

To set the streaming channel

1. In the **Dashboard** pane, activate **AV Streaming**.
2. Set the input source of the AV (**HDMI or USB-C**).
3. Update the **Channel ID**:
 - Channel assignation is automatic. To manually set a channel number use the arrows or click on the box (1 - 999).
 - The same channel ID must be set on the decoder.

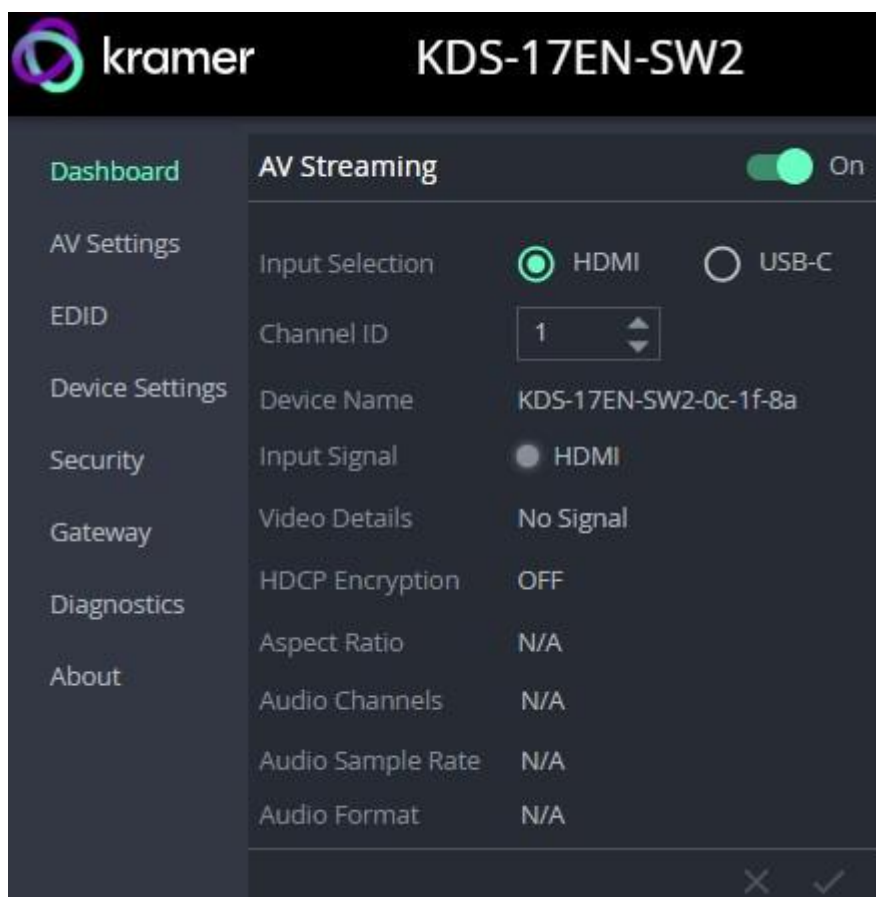

4. Additional non-editable fields are displayed to describe the input AV:
 - **Device Name** – The network host name. Can be updated in Device > General.
 - **Input Signal** – Source of the input video.
 - **Video Details** – Input video's resolution.
 - **HDCP Encryption** – Is HDCP active, (High-bandwidth Digital Content Protection) used to protect copyrighted material.
 - **Aspect Ratio** – Aspect ratio of the input video.
 - **Audio Channels** – Number of channels in audio input.
 - **Audio Sample Rate** – Input audio signal's sample frequency (number of samples per second).
 - **Audio Format** – LPCM (uncompressed audio), NLPCM (compressed), HBR (compressed high bit rate, such as Dolby TrueHD).
5. Click the green check to confirm the changes; The streaming channel is changed.

To Preview the AV Stream

In the **Dashboard** pane, activate **AV Streaming Preview**.

The AV Streaming Preview aspect ratio, FPS and bandwidth can be changed in **AV Settings > Video** (see [Preview: Set the parameters of the Dashboard's preview stream. on page 23](#)).

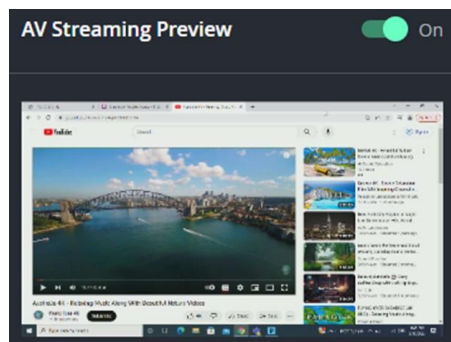

Audio Output Settings

Audio Streaming - To output a Dante or AES67 audio stream (digital audio over Ethernet), activate **Dante / AES67 OUT**.

Analog - Volume and **Mute** control the analog audio output (if used). The analog audio direction must be set in **AV Settings > Audio** (see [Defining Analog Audio Direction: on page 23](#)).

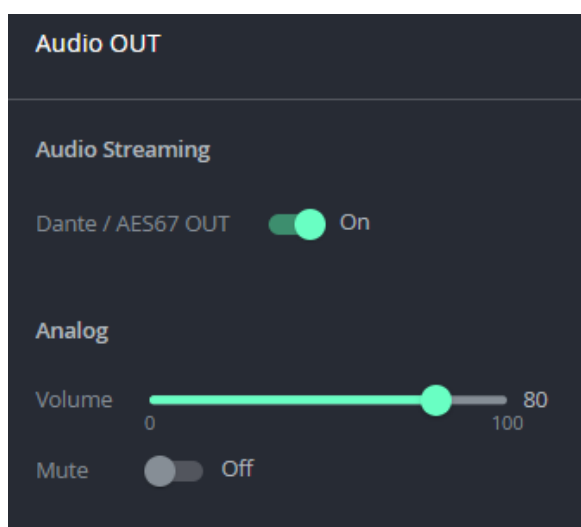

Set the Source for Audio Output Options

- In the **Dashboard** pane's **Device Audio Routing** field group, choose the audio input for each potential audio output option.

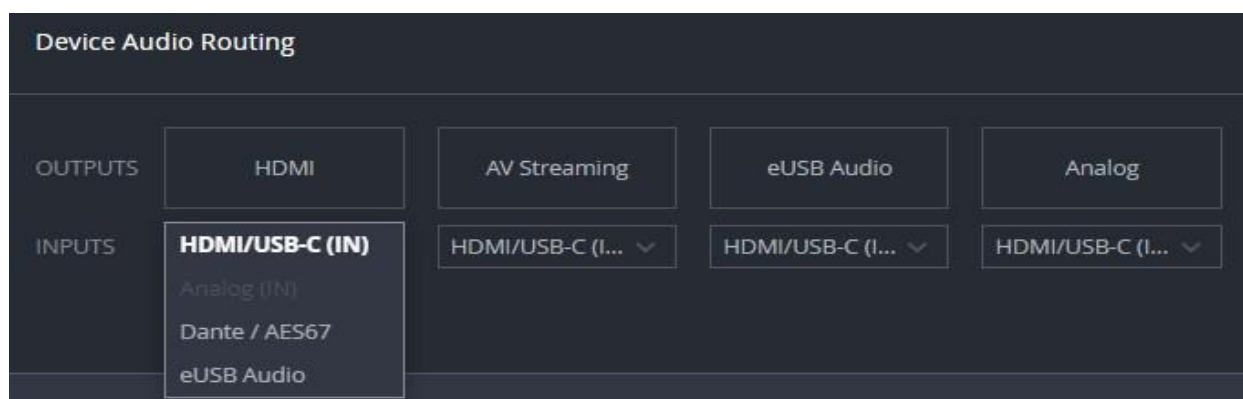

For more information on inputting Dante / AES67 audio, see [Defining Dante or AES67 Audio as an Audio Source or Destination on page 43](#).



The analog audio direction must be set in **AV Settings > Audio** (see [Defining Analog Audio Direction: on page 23](#)). Analog can be input or output, but not both.

AV Settings: Define Video and Audio Output

Set the output AV stream's settings. There are three tabs: **Video**, **Audio** and **Auto Switch**.

Video tab: Define video output

1. Select the **AV Settings** pane. The **Video** tab opens.

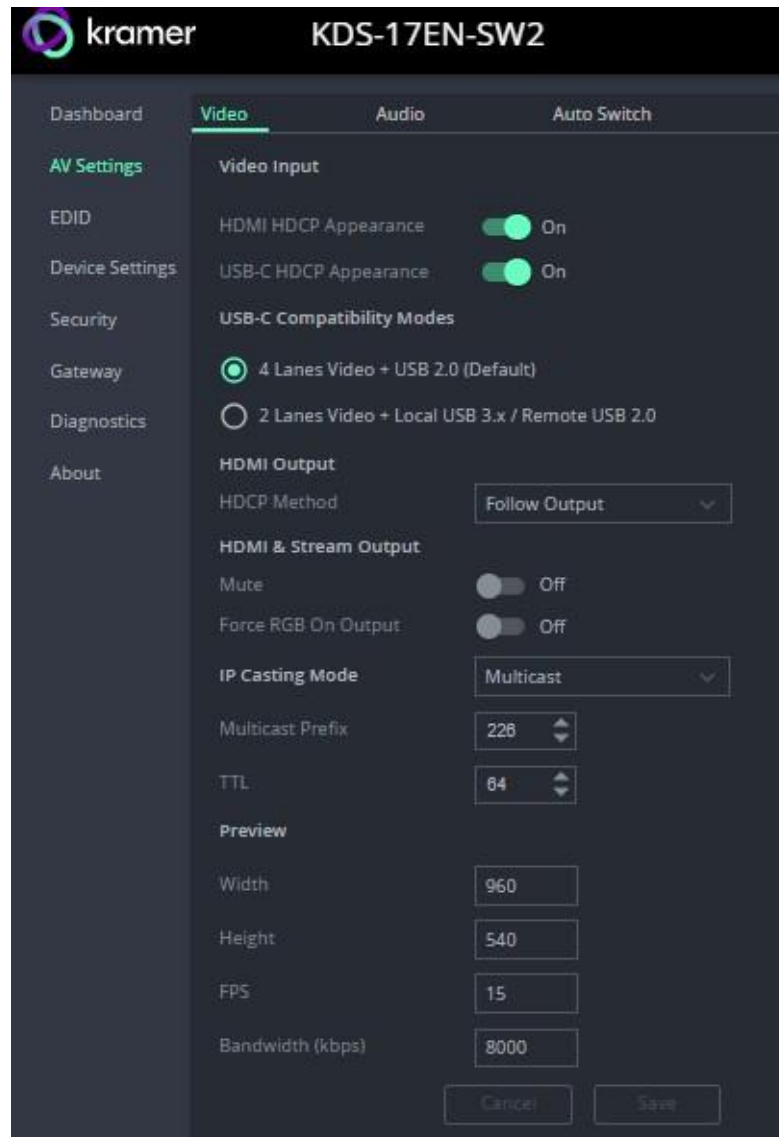

2. **Video Input** (HDCP setting):

- **HDMI HDCP Appearance:** Enable (default) or disable HDCP encryption for HDMI input.
- **USB-C HDCP Appearance:** Enable (default) or disable HDCP encryption for USB-C input.

3. **USB-C Compatibility Modes** (select the number of USB "lanes" used for video):

- **4 Lanes Video + USB 2.0 (default)** - Best used for display port cables which support high-definition "4 lane" data transmission.
- **2 Lanes Video + Local USB 3.x / Remote USB 2.0** - This option provides for "2 lane" data transmission over (high-speed) USB 3.0, while retaining support for USB peripherals such as a video camera.

4. **HDMI Output**- Set the **HDCP Method**: Follow Output / Follow input (activation of HDCP will be set by the destination device or by the input device).
5. **HDMI & Stream Output** -
 - **Mute** - Disable audio on HDMI and stream.
 - **Force RGB on Output** - Splits the red/green/blue output signals into separate channels. On some screens this produces a better picture.
6. **IP Casting Mode** -
 - **Unicast / Multicast** (default) – Multicast communication transmits the data stream to multiple receivers simultaneously, select unicast if your stream is intended for a single receiver.
 - **Multicast Prefix** – Select a prefix for the multicast stream's IP between 224 and 239 (default prefix is 226.x.x.x). Routers identify multicast streams by their IP prefix and handle the stream's packets as data which is not directed to a specific recipient: It is a general stream addressed to the entire network.
 - **TTL** - Time To Live (TTL) restricts the number of times a packet/data can be forwarded by network routers before it is discarded. It stops the stream data from circulating endlessly in the network. Select a value between 1 and 255 (Default 64).
7. **Preview**: Set the parameters of the Dashboard's **preview stream**.
 - **Width** – 1 to 1280 (default 480).
 - **Height** – 1 to 720 (default 270).
 - **FPS**- 1 to 60 (default 4).
 - **Bandwidth** – 1 to 50,000 (default 2000).
8. Click **SAVE**.

Audio tab: Define Audio Output

Set the source of the encoder audio input and method used to output the audio.

Defining Analog Audio Direction:

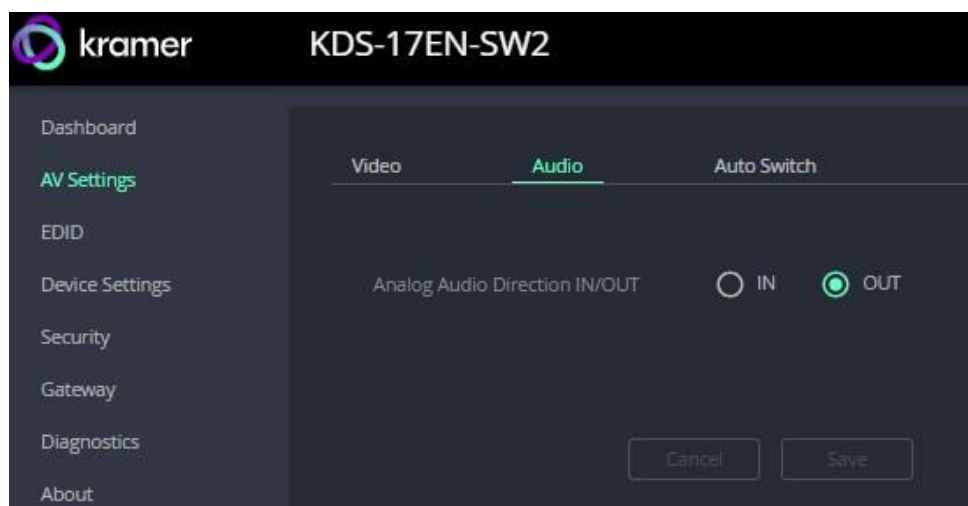

- **Analog Audio Direction IN/OUT** - Select IN (default) or OUT. Analog audio uses the encoder's 5-pin terminal block connector (14 in [Defining KDS-17EN-SW2 on page 6](#)). It can only be in one direction (in or out), which must be specified.

Click **SAVE** after changing settings.

Auto Switch tab

The Auto Switch tab sets how KDS-17EN-SW2 switches between streams delivered to the HDMI input and/or the USB-C input.

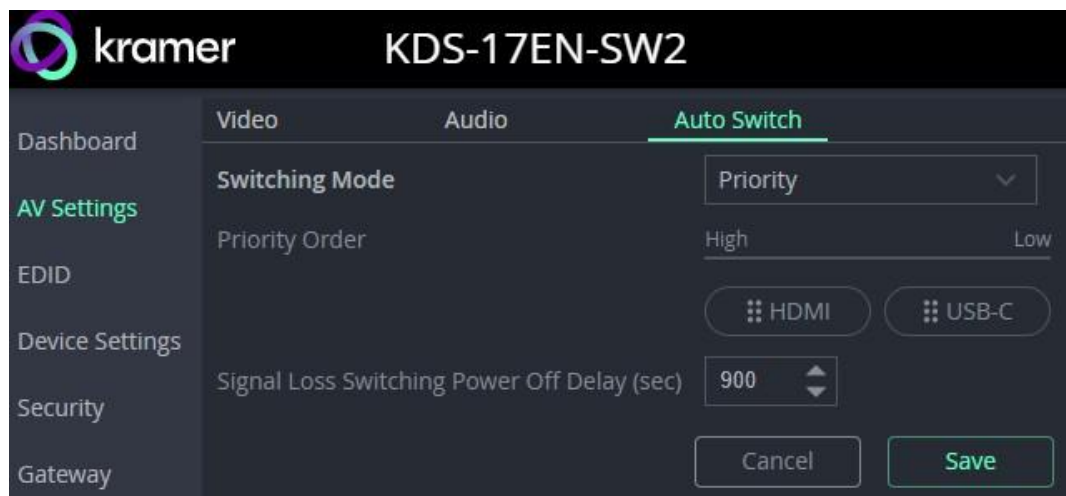

- **Switching Mode** - Select the preferred method of switching between inputs:
 - **Priority** - This option prioritizes the stream defined as high priority in the **Priority Order** field. If only the low priority input is streaming, then it is used.
 - **Last connected** - The device automatically streams the last used input. It switches to the other input if no stream are detected (and the other input is streaming).
 - **Manual** - The device will only ever stream the input source selected in the Dashboard. To change the input source the Dashboard must be updated.
- **Priority Order** - Click and drag the 6 dots to switch the priority of HDMI and USB-C.
- **Signal Loss Switching Power Off Delay (sec)** - The delay time in seconds between when the device detects signal loss and when it stops 5V power output.

Click **Save** after making changes.

EDID: Setting Display Metadata

EDIDs (Extended Display Identification Data) are metadata sent from HDMI display devices which describe their formatting and capabilities. The EDID is used to adjust output sent to the display device, so that it matches the display's requirements. KDS-17EN-SW2 can retrieve an EDID from a remote display (connected to the decoder), use the predefined default EDID or upload a custom EDID from a connected computer.

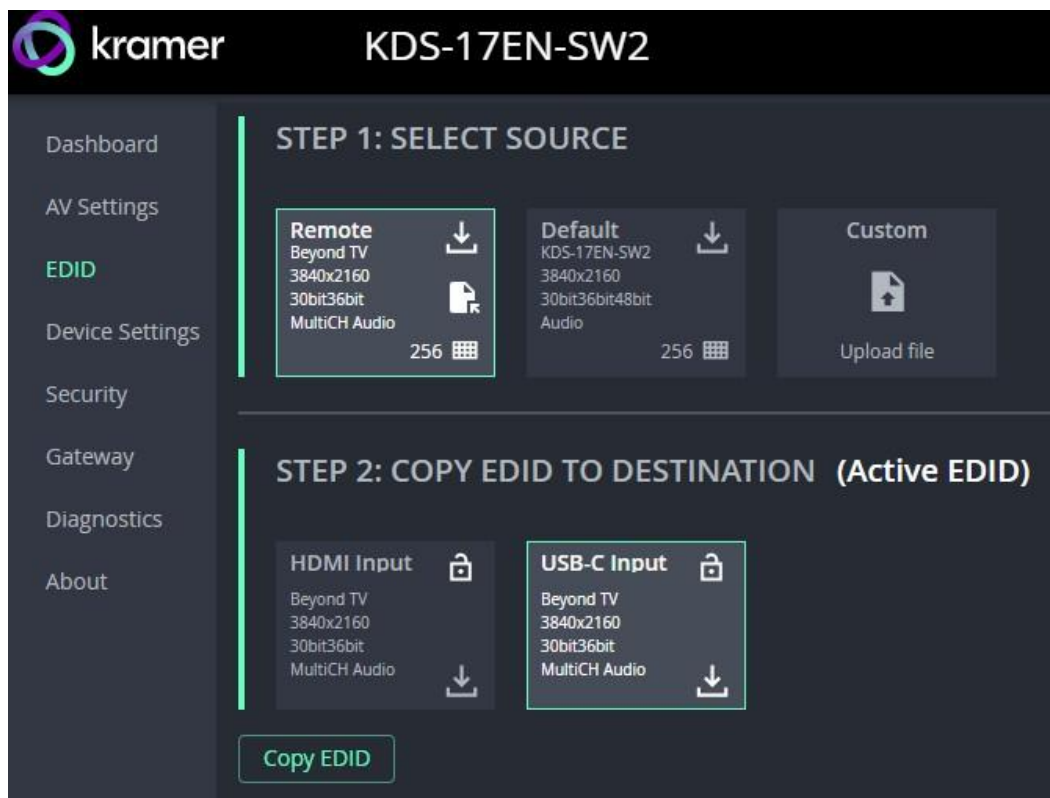

Step 1: Select Source.

To set an EDID, click on a **Select Source** square and then click **COPY EDID** at the bottom; The selected EDID will be copied to **Step 2**.

Select Source options:

- **Remote** – Opens a pop-up for entry of the desired decoder's IP address. The EDID of the screen connected to the HDMI Out port of the selected decoder will be returned to the device. Click the download icon to store it on your computer.
- **Default** – A default EDID is supplied with the KDS-17EN-SW2. Click the bottom right corner to view the EDID bitmap. Click the download icon to store it on your computer.
- **Custom** - Upload a stored EDID file from your computer.

Step 2: Copy EDID to Destination

Click **COPY EDID** and your selected EDID will be loaded into Step 2.

EDID is managed.

Device Settings: General, Network, Time & Date

The KDS-17EN-SW2 **Device** pane has three tabs:

- **General** – Sets the KDS-17EN-SW2 host name, updates firmware, restarts or resets the device. You can also export or input the device settings.
- **Network** – Setup the LAN 1 and LAN 2 streams.
- **Time & Date** – Define an NTP (network time protocol) server or set the time. An NTP server is advisable, as it coordinates the time between all the connected devices.

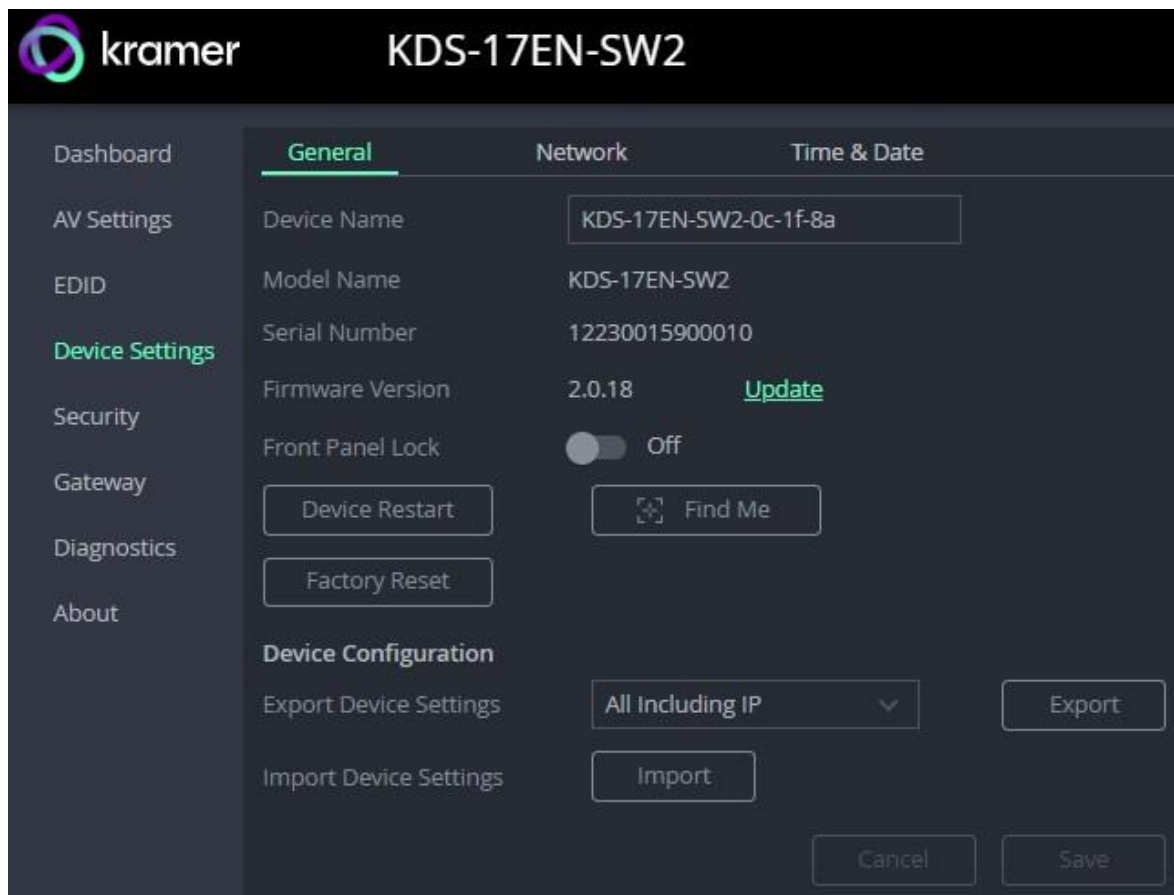

The screenshot displays the web interface for the Kramer KDS-17EN-SW2 device. The interface is dark-themed and features a sidebar on the left with navigation options: Dashboard, AV Settings, EDID, Device Settings (highlighted in green), Security, Gateway, Diagnostics, and About. The main content area is titled 'KDS-17EN-SW2' and has three tabs: General (selected), Network, and Time & Date. Under the General tab, the following settings are visible:

- Device Name:** KDS-17EN-SW2-0c-1f-8a
- Model Name:** KDS-17EN-SW2
- Serial Number:** 12230015900010
- Firmware Version:** 2.0.18, with an [Update](#) link.
- Front Panel Lock:** Off (toggle switch).

Below these settings are two buttons: **Device Restart** and **Find Me**. Under the **Device Configuration** section, there are buttons for **Export Device Settings** (with a dropdown menu set to 'All Including IP') and **Import Device Settings** (with an **Import** button). At the bottom right, there are **Cancel** and **Save** buttons.

General tab

The screenshot shows the 'General' tab of the Kramer KDS-17EN-SW2 web interface. The left sidebar contains navigation links: Dashboard, AV Settings, EDID, Device Settings (highlighted), Security, Gateway, Diagnostics, and About. The main content area is divided into three sections: General, Network, and Time & Date. Under the General section, there are fields for Device Name (KDS-17EN-SW2-0c-1f-8a), Model Name (KDS-17EN-SW2), Serial Number (12230015900010), and Firmware Version (2.0.18) with an 'Update' button. There is a 'Front Panel Lock' toggle switch set to 'Off'. Below these are buttons for 'Device Restart', 'Factory Reset', and 'Find Me'. The 'Device Configuration' section includes 'Export Device Settings' (with a dropdown menu set to 'All Including IP' and an 'Export' button) and 'Import Device Settings' (with an 'Import' button). At the bottom right are 'Cancel' and 'Save' buttons.

- **Device name** – Edit or view the device’s Host name (default is <model>-<MAC>).
- **Model Name** of the encoder.
- **Serial Number** of the encoder.
- **Firmware Version** – To update the encoder firmware, download the latest version from <http://www.kramerav.com/downloads/KDS-17EN-SW2> to a local network location and then click **Update** to select and upload it.
- **Front Panel Lock** – Enabling this option prevents use of the LCD Display.
- **Device Restart** – Click to restart KDS-17EN-SW2 (confirmation will be requested).
- **Factory Reset** - Click to reset the device's operation mode and restart the device (confirmation is requested).
- **Find Me** – The LEDs will flash fast for 60 seconds to identify the device.



When an HDMI OUT screen is connected without input, the screen shows the device’s IP.

- **Device Configuration** –
 - **Export Device Settings** – Outputs a settings file with the name “settings.tar.gz”. The output file is in JSON format. Output options are All Including IP, All excluding IP and AV Settings Only.
 - **Import Device Settings** – Imports a settings file in the same format as the output file (tar.gz). The device will be reset to the uploaded settings.

Click **Save** to store changes or update settings.

Network tab: Using LAN 1 and LAN 2 for different streams

KDS-17EN-SW2 has two Ethernet ports, LAN 1 and LAN 2 (11 and 12 in [Defining KDS-17EN-SW2 on page 6](#)). By default, all network connections use LAN 1. Different stream types can be separated and sent to/from each port using different IP addresses for each port.

For example, use one port for AV and the other for P3K (P3000 API) control commands.

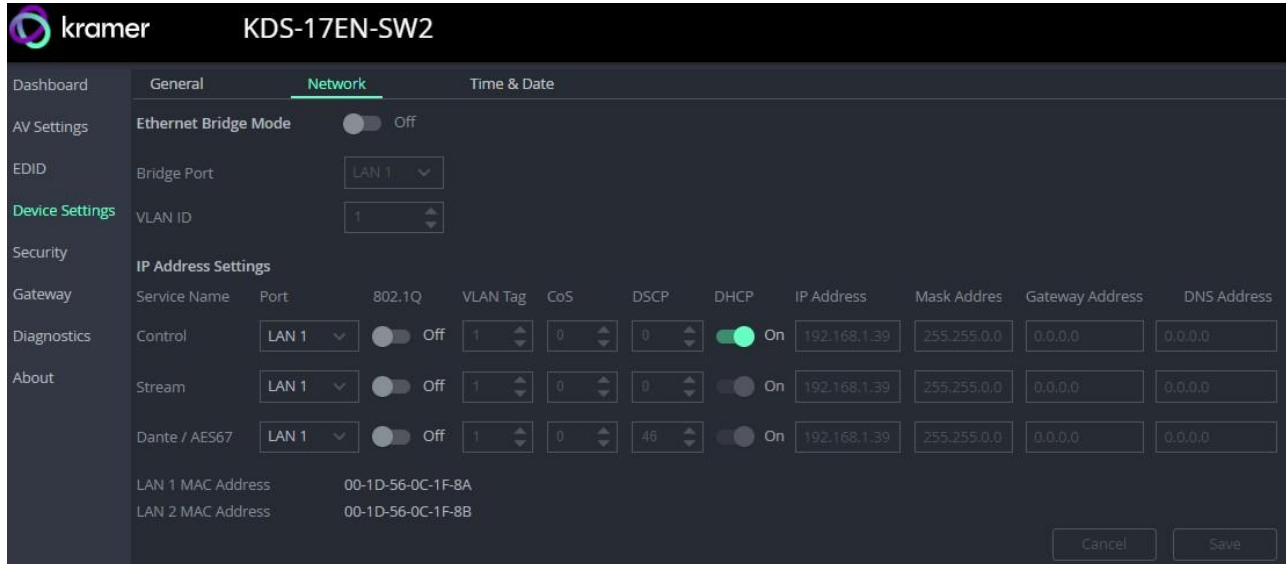

- **Ethernet Bridge Mode** – Enables a connected third party device to access the network.
 - **Bridge Port** – LAN 1 or LAN 2. When enabled, Control, (AV) Stream and Dante / AES67 streams cannot use the Bridge port and cannot be separated to different ports.
 - **VLAN ID** – Ethernet data tagged with the VLAN ID will be allowed to reach the bridge port.

IP Address Settings

- **Service Name** –
 - **Control** is for PK3000 commands, RS-232 and IR data.
 - **Stream** is for the AV stream.
 - **Dante / AES67** is for transmitting high-quality digital audio (including AES67 audio) over Ethernet.
- **Port** – LAN 1 or LAN 2. The Ethernet port used by the service.
- **802.1Q** – If set to On (off by default), the data transmission uses VLAN tags.
 - **VLAN Tag** – VLAN (virtual local area network) tags (range 2 – 4000) are used to separate the network into smaller virtual networks. Requires 802.1Q to be set to On. If Ethernet Bridge Mode is enabled, none of the streams can use their VLAN ID.
 - **CoS** – Class of Service, requires a unique VLAN tag. CoS sets the priority (0-7) of each of the VLAN options within the local network (layer 2 of the OSI model). Higher priority traffic is prioritized and provides a more reliable service.

If the stream and the control share the same LAN, the stream will follow control configuration. Dante / AES67 always use CoS 0.

- **DSCP** – The DSCP (Differentiated Services Code Point) value is used to mark the priority (0-63) of packets in a WAN network layer (layer 3 of the OSI model). It is used for large-scale networks (or across the Internet) and increases the quality of service. By default DSCP is 56 for the Control stream and 46 for Dante / AES67. Dante always has a DSCP of 46 (even if 802.1Q is off).
- **DHCP** – If set to On, the service's IP address is generated automatically. If set Off, you may need to define a static IP address for the service.

To separate Control streams from AV streams

1. Change the following settings in the **IP Address Settings** section of the **Network** tab (see the image above for more information):
 - In the **Control** row's **Port** column select **LAN 2** and set **802.1Q** to **On**.
 - In the **VLAN Tag** column, enter an integer number (2 - 4000) for Control services. This separates the Control packets.



802.1Q and VLAN are not required for the Media port.

2. To use a static IP for LAN 2, set DHCP to Off and enter a subnet mask and gateway address. If no DHCP server exists in the system, the device will look for a random unique IP in the range of 192.168.0.0-16. The allocated IP address is shown in the IP address field.

To separate Dante/AES67 Audio from the AV streams

If **Ethernet Bridge mode** is enabled, the Audio and Visual streams cannot be separated.



For more information see, [Defining Dante or AES67 Audio as an Audio Source or Destination on page 43](#).

1. To export Dante or AES67 (digital) audio from the encoder, you must first go to the KDS-17EN-SW2 **Dashboard** pane and set at least one of the **Device Audio Routing INPUTS** to Dante (see [on page 21](#)).
2. In the KDS-17EN-SW2 Device Settings pane, open the Network tab (see Figure 20).
3. In the **IP Address Settings**, set the **Dante / AES67** row's **Port** column to LAN 2.
4. If you are using **802.1Q** network security set it to **On**.
In the **VLAN ID** column, enter an integer number between 2 and 4000 for Dante / AES67. Make sure this is different from the number used for the Control packets.
5. The **CoS** and **DSCP** values are set by the system and are not configurable.
6. To use a static IP for LAN 2, set DHCP to **Off** and enter a subnet mask and gateway address.

Dante/AES67 audio output is now defined.

Time & Date tab

To sync device time and date from a network time server:

1. In the **Device** pane, select the **Time & Date** tab. If no NTP Time Server is defined, the time will be set to 1970 every time the device reboots.
2. Set the **Time zone**.
3. Set **Use Time Server (NTP)**, to On.
4. Enter the **Time Server Address** IP or URL.
5. Click the green arrows  to check that the server is available.
6. Click **SAVE**.

The devices date and time are synchronized to the server address entered.

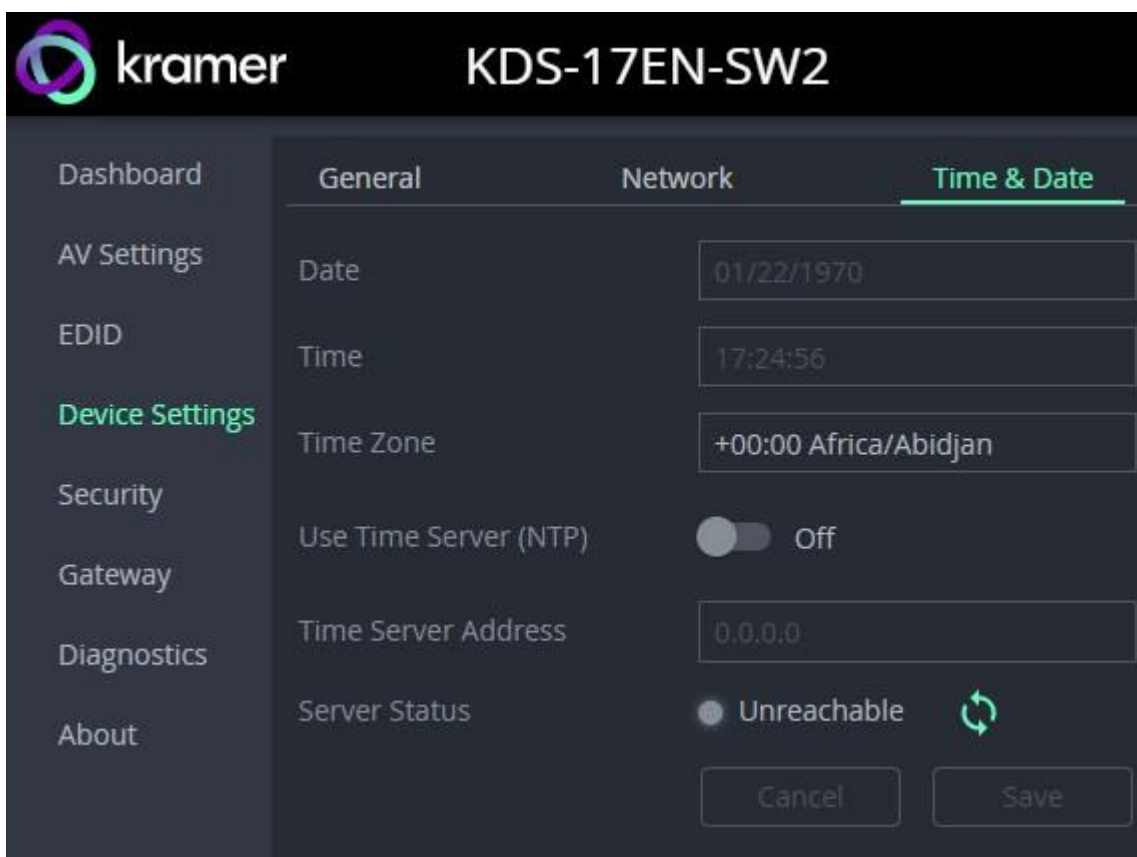

Security: Passwords, HTTPS, 802.1X and AES256

Password protection of the web pages is only active when the Security Status is On (the default state). The default password is “admin”.



If you change the password, the new password must include a number, a special character and both upper and lower case letters (no commas or spaces).

The KDS-17EN-SW2 **Security** pane has four tabs:

- **Device Security** – Enable/disable security and change the device password.
- **HTTPS** – Use the device’s internal certificate or upload a local certificate.
- **802.1X**- Enable and setup IEEE 802.1X authentication.
- **AES256** – Set the level of AES256 encryption.

Device Security tab: Enable Password Control

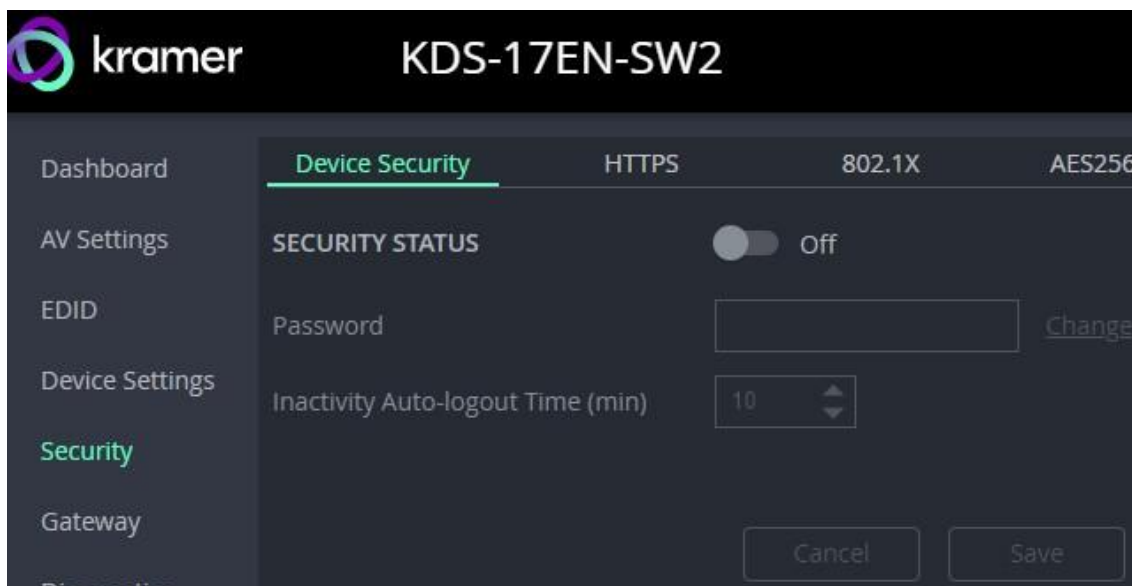

To change Security Status

Move the slider to enable/disable security.

When security is enabled, access to the web pages requires entry of a password. Changes to the security status require entry of the device’s current password (default: “admin”).

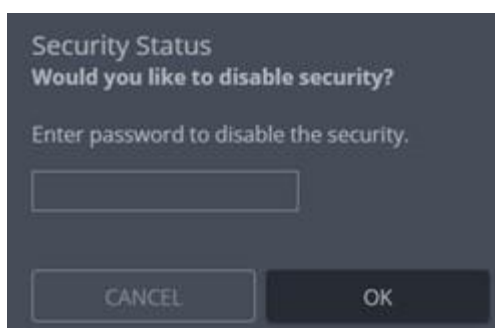

Inactivity Auto-logout Time (min) - Users will be automatically logged out of the embedded web pages if no activity is detected.

To change the password

Password protection is only available if the **Security Status** is On. To change the password, enter the **Current Password** and then click **Change**.

The new password must include a number, a special character and both upper and lower case letters (no commas or spaces).

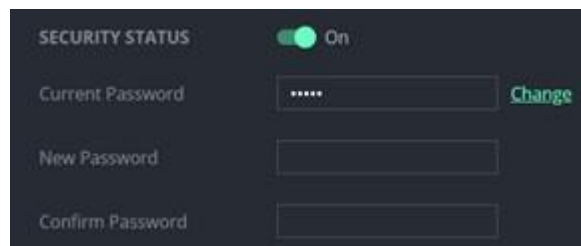

HTTPS tab

To configure HTTPS:

1. In the Security pane's **Device Security** tab, **Security Status** must be enabled.
2. Select the **HTTPS** tab.
3. Select one of the following authentication methods:
 - **Internal Certificate** – Use the factory default certificate for authentication.
 - **Server Certificate** – Upload an authentication certificate from the server (assigned by your network administrator). Click  to upload the certificate. Enter the private key password.

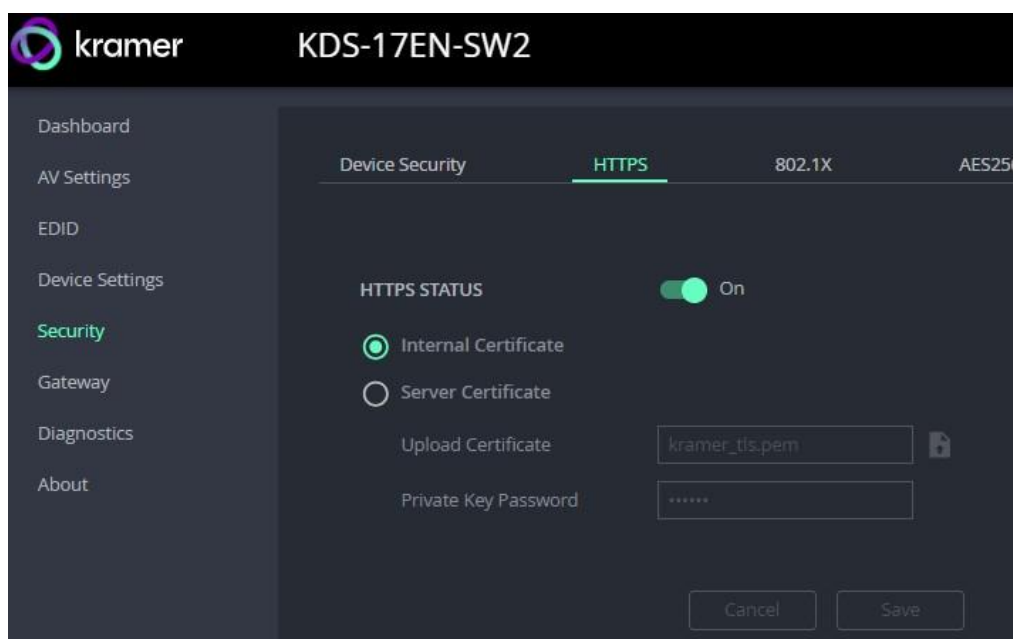

4. Click **SAVE**.

HTTPS is configured.

802.1X tab



802.1 X authentication must be defined separately for LAN 1 and LAN 2. 802.1X is a port-based authentication protocol, that uses a RADIUS network access server to authenticate devices accessing the network. It must be configured separately for LAN 1 and LAN 2.

To configure IEEE 802.1X Authentication:

1. In the Security pane, select the 802.1X tab.



LAN 1 / LAN 2 - LAN 2 has identical settings and is at the bottom of the screen. Enable and configure LAN 1 and LAN 2 separately.

2. Set 802.1x authentication **ON**.
3. **Authentication Status:**
 - Green – LAN is using 802.1X and authentication has succeeded.
 - Orange – LAN is using 802.1X and authentication is in process.
 - Red – LAN is using 802.1X but authentication has failed.
 - Grey – 802.1X is disabled.
4. Check one of the following settings:
 - **EAP-MSCHAP V2** – To use this authentication method, enter the KDS-17EN-SW2 username and password.
 - **EAP-TLS** – Submit a certificate from your network authentication server. To do so, enter the KDS-17EN-SW2 Username (“admin”) and click  to upload the Client Certificate and Private Key. Enter the Private Key Password (assigned by your network administrator).
5. **Server Certificate** – (optional) Use a CA (certification authority) issued certificate to authenticate the RADIUS server. Enable and click  to upload the CA certificate.

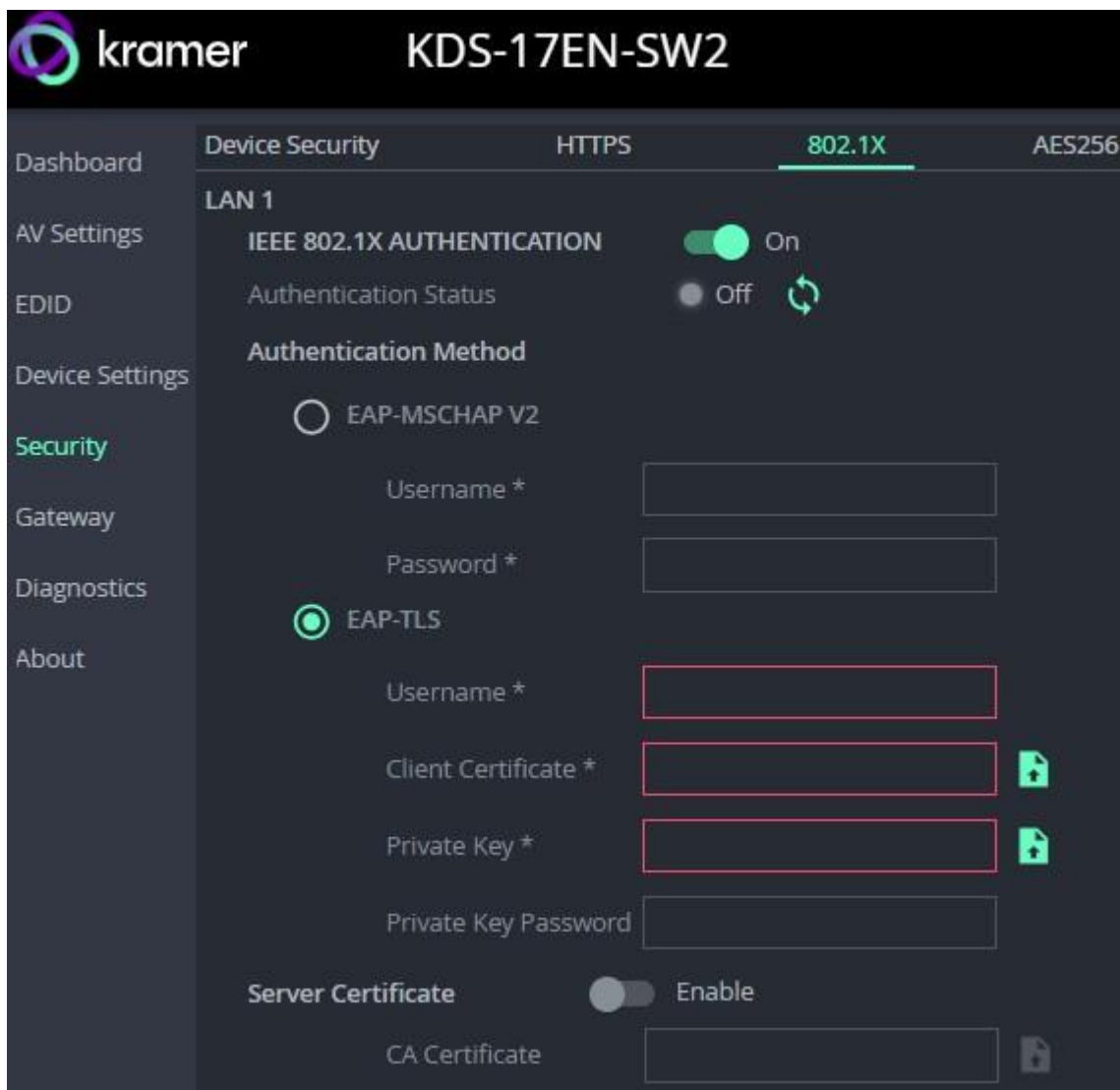

6. Repeat for **LAN 2** if necessary.
7. Click **SAVE**: 802.1X is configured.

AES256 tab

When Device Security is enabled, AES256 encryption is used to encrypt packet headers, Use AES256 Full to encrypt the whole packet. By default, a system key is used for encryption and decryption. If you want to enter a custom key, key make sure both encoder and decoders are updated to use the same key.

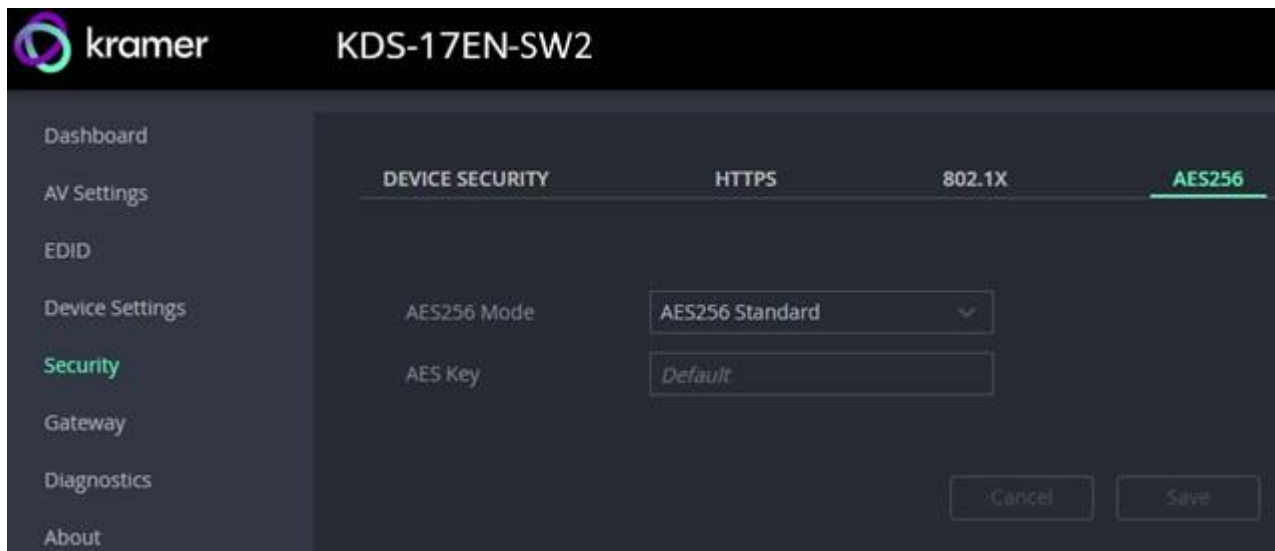

AES256 Mode: Standard or Full.

- **Standard** encrypts the packet headers into blocks of 128 bits each.
- **Full** encrypts the entire packet and requires that Jumbo Frames are enabled on the switch, so that the transmitted IP packet is not larger than the maximum Ethernet frame.

AES KEY: Default or customized.

- **Default** uses 14 rounds of processing to create a device defined 256 bit key.
- **Customized** requires you to enter a 32 byte hexadecimal string (64 characters using only the characters 0 – 9 and A to F). No hex code identifier is required before the string.

Gateway: CEC, RS-232 and IR definitions

The KDS-17EN-SW2 Gateway pane has three tabs:

- **CEC** – Enable and setup direction of CEC commands.
- **RS-232** – Enable and configure the use of RS-232 communication.
- **IR** - Setup direction of pass-through IR (infrared) controls.

CEC tab: Configuring CEC commands

CEC (Consumer Electronics Control) are commands that HDMI devices can send to connected devices, so that controls sent to a single device are used to control multiple connected devices.

KDS-17EN-SW2 can send CEC commands over LAN to CEC enabled devices that are connected to a KDS-17DEC.

If you are sending CEC commands from an external source, set **GATEWAY** Off and set **Passthrough HDMI IN with** to **Decoder HDMI Output**. To output the CEC commands to the encoder's HDMI output, use **Local HDMI Output**.

If you want to send CEC commands from the embedded webpages, enable GATEWAY.

To set CEC Gateway:

1. In the Gateway pane, click **CEC**.



2. **Enable** the CEC gateway.
3. Select the Gateway HDMI port to which CEC commands are sent (HDMI input or HDMI output).
4. Click refresh  , to see the address of the CEC device attached to the HDMI port.
5. Enter the CEC command in hexadecimal format.
6. Click **SEND**.
7. View the CEC-enabled device response in the **CEC Notifications** field.

RS-232 tab

KDS-17EN-SW2 can receive RS-232 commands over LAN, that were sent to a connected decoder's RS-232 port. These commands can be used to remotely control KDS-17EN-SW2.

To set RS-232 Gateway:

1. In the Gateway pane, click the **RS-232** tab.

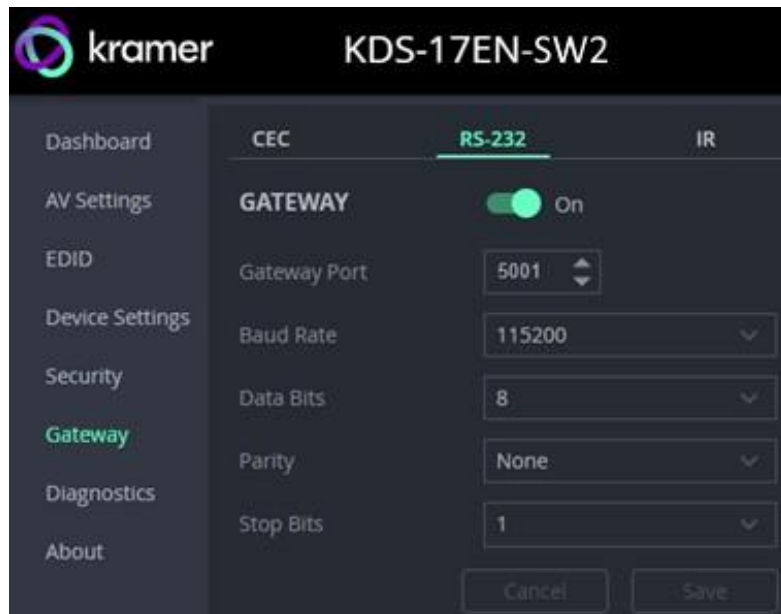

2. Click **Enable** to enable RS-232 gateway or click **Disable**.
3. Define the RS-232 gateway port (5001, by default).
4. Enter the Baud Rate: 1200 to 115200 (default).
5. Enter the Data Bits: 5, 6, 7 or 8 (default).
6. Enter Parity: None (default), Odd or Even.
7. Enter Stop Bits: 1 (default) or 2.
8. Click **SAVE**.

RS-232 Gateway is configured.

IR tab

KDS-17EN-SW2 can send or receive IR commands over LAN, to or from a connected decoder. The IR signals can be used to control a relevant device and the direction should be the opposite of that specified on the connected decoder.

To set IR Gateway:

1. In the Gateway pane, select the IR tab.

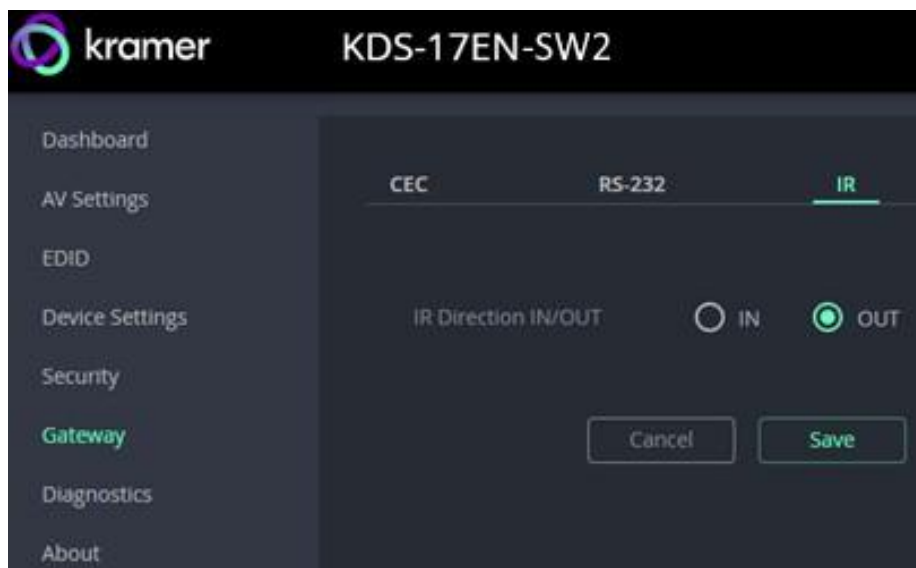

2. Set IR direction:

- **IN** – Configure the IR port as an input port that is connected to an IR receiver cable.
- **OUT** – Configure the IR port as an output port that is connected to an IR emitter cable.

3. Click **Save**.

IR Gateway is configured.

Diagnostics: Status, Connections and Logging

The KDS-17EN-SW2 **Diagnostics** pane has three tabs:

- **STATUS** – View the device's activity state, temperature, and output ports.
- **CONNECTION** – View the device's active network connections.

Status tab

1. In the Diagnostics pane, click **Status**.

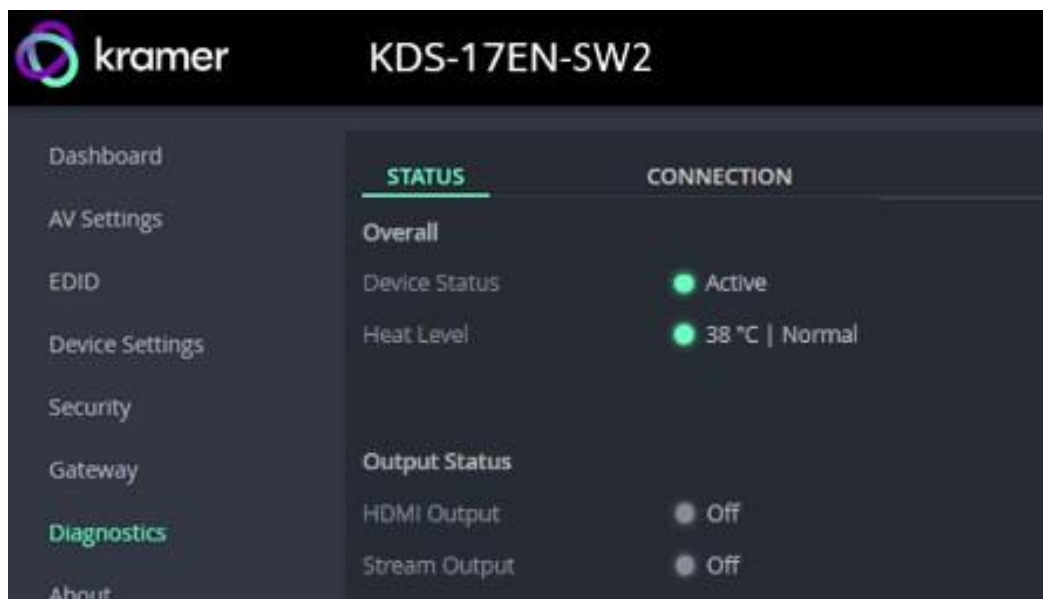

2. Device Status:
 - **Active**, for normal operation (green indication).
 - **Standby**, when device is powered off, booting or in standby mode.
3. Heat Level:
 - **Normal**, for temperatures below 45°C.
 - **High**, for temperatures between 45°C and 60°C.
 - **Overheat**, for temperatures above 60°C.
4. View the status of the outputs:
 - **HDMI OUT** - On, the output channel is transmitting an active signal.
 - **Stream Output** – On, a signal is being transmitted.

Device status is viewed.

Connection tab

View the network devices connected to KDS-17EN-SW2.

To view Connections status:

1. In the Diagnostics pane, click **Connection**.

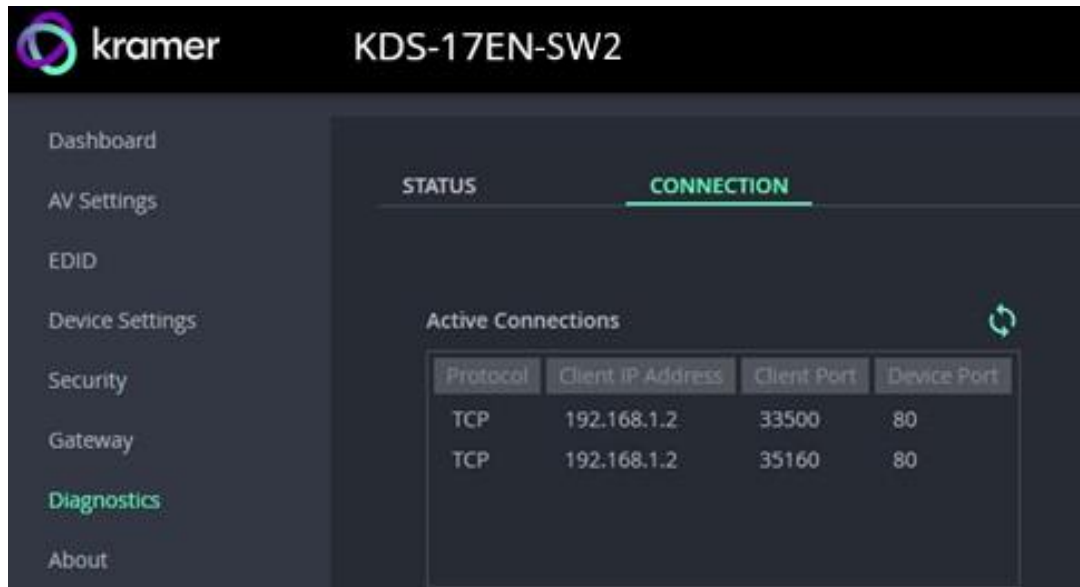

2. Select the Connections tab.
3. UDP devices that end the connection will be displayed for 10 minutes after the connection ends.

Connections' status is viewed.

About

View the device model, hardware release, firmware version and Kramer Electronics Ltd details.

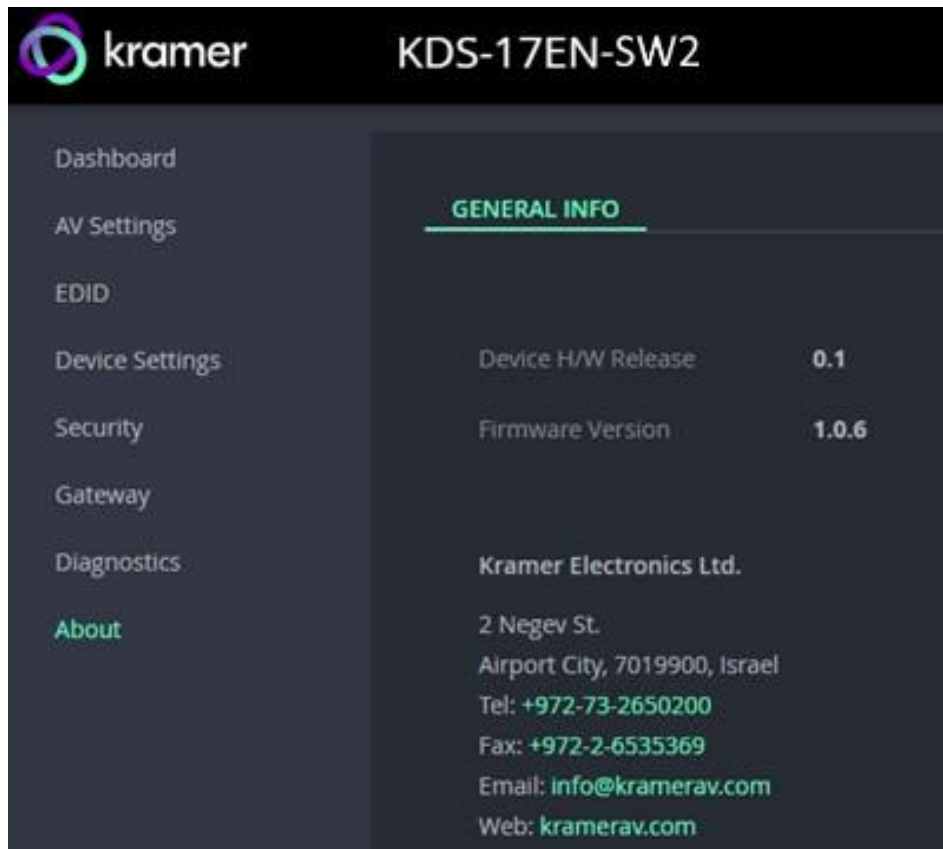

The screenshot shows the 'About' page of the Kramer KDS-17EN-SW2 device. The page has a dark theme with a sidebar on the left containing navigation links: Dashboard, AV Settings, EDID, Device Settings, Security, Gateway, Diagnostics, and About (highlighted in green). The main content area is titled 'GENERAL INFO' and displays the following details:

Device H/W Release	0.1
Firmware Version	1.0.6
Kramer Electronics Ltd.	
2 Negev St.	
Airport City, 7019900, Israel	
Tel: +972-73-2650200	
Fax: +972-2-6535369	
Email: info@kramerav.com	
Web: kramerav.com	

Upgrading Firmware

Upgrade the firmware, view the date of the last upgrade, or rollback to the previous firmware revision in case of a problem.

To upgrade the firmware:

1. In the Navigation pane, Select **Device Settings**. The General tab in the Device Settings page appears.

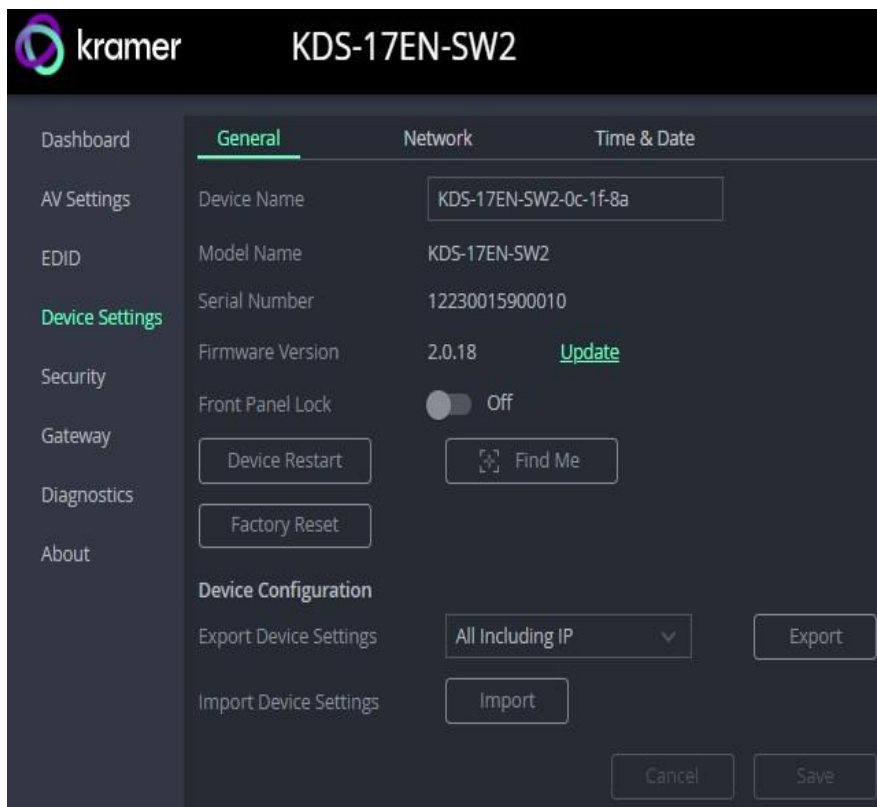

2. Next to Firmware Version, click **Update**. The Open window appears.
3. Select the FW file and click **Open**. The FW upgrade pop-up window appears. Wait for upgrade completion.
4. Once completed, refresh the web page and log-in.

Firmware upgrade is complete.

Defining Dante or AES67 Audio as an Audio Source or Destination

Dante (Digital Audio Network Through Ethernet) is a professional digital audio over Ethernet technology (AoE) developed by Audinate, which is designed for transmission of multiple audio channels over relatively long distances or to many locations. It is considered well-suited for live sound and large installations.

AES67 is an open standard network protocol for AoE interoperability defined by the Audio Engineering Society (AES) which makes different types of AoE systems compatible with each other.

Defining Dante input to the KDS-17EN-SW2 encoder

KDS-17EN-SW2 can import a Dante audio stream and output it to the decoder.

1. In the KDS-17EN-SW2 webpages, open the KDS-17EN-SW2 **Dashboard** pane.
2. In the **Audio OUT** field group, set **Dante / AES67 OUT** to On.
3. In the **Device Audio Routing** field group, set the relevant **INPUTS** to **Dante / AES67** (see [on page 19](#)).
4. Open the KDS-17EN-SW2 **Device Settings** pane and select the **NETWORK** tab.
5. In the NETWORK tab's **IP Address Settings** field group, find the **Dante / AES67** row and set the relevant settings (see [Using the KDS-17EN-SW2 Embedded Web Pages on page 19](#)).

Using Audinate Dante Software

To input Dante or AES67 audio to KDS-17EN-SW2:

1. Download and install Dante Controller software from <https://my.audinate.com/support/downloads/dante-controller>.
2. Open **Dante Controller** software on a laptop connected to the same LAN switch as KDS-17EN-SW2. Dante Controller opens in **Network View** with the **Routing** tab open and lists the Dante enabled devices it has detected on the network. Receivers are shown on the left and transmitters on the top.
 - **To connect a unicast flow** (stream) between a transmitter and receiver click on the intersection between them.
 - **To create a multicast flow:**
 - a. Open the **Device Info** tab.
 - b. Double click the KDS-17EN-SW2 device to open the **Device View** screen.

Device Name	Model Name	Product Version	Dante Version	Device Lock	Primary Address	Primary Link Speed	Second Address
KDS-17EN-SW2	KDS-17EN-SW2001D9CA	1.1.0	1.0.5.6		10.0.254.33	1Gbps	N/A
KDS-17DEC	KDS-17DEC001D914	0.0.1	4.2.6.5		10.0.254.60	100Mbps	N/A

- c. If using AES67, click the **AES67 Config tab** and enable AES67 Mode; You will be prompted to reboot (restart) **Dante Controller** (repeat steps a and b after restarting).



- d. Select the **Receive tab** and click the Flow icon to create an audio flow (stream).



- e. The **Create Multicast Flow** dialog box opens. Select the flow type (Dante or AES67), the channels and press the **Create** button.

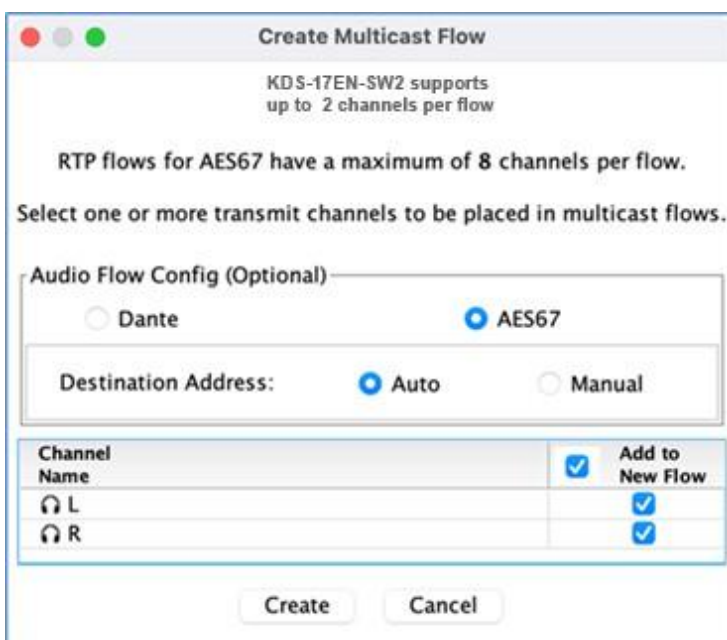

- f. An RTP multicast flow is created and will be visible in **Transmit tab**.

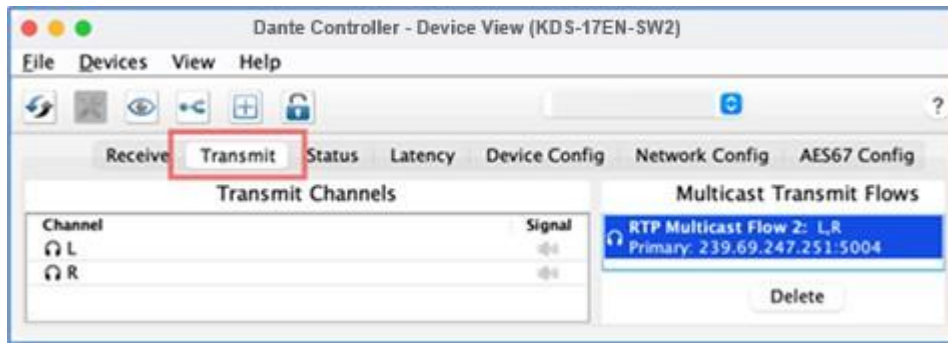

- g. Use the **Dante Controller** software to route the audio between the encoder/decoder and the Dante source or destination.

Dante / AES67 are defined.

Technical Specifications

Inputs	1 HDMI	On an HDMI female connector
Outputs	1 HDMI	On an HDMI female connector
Ports	1 Ethernet	On an RJ-45 connector
	1 Ethernet	On an SFP optical or copper transceiver port
	1 Balanced Audio	On a 5-pin terminal block connector
	1 RS-232	On a 3-pin terminal block connector
	1 IR	On a 3.5mm TRS connector
USB	1 USB-B Host	Connecting USB 3.0 PC/Laptop
	1 USB-C Host	Connecting USB 3.0 PC/Laptop. Charges connected hosts that support USB Power Delivery 2.0, up to 60W, when the device is powered by the optional PS-2006 20V DC power adapter. Transmits audio and video signals.
	2 USB-A Devices	Connecting USB 3.0 local devices
	2 Level USB Hub	Connecting to KDS-17DEC
Network	Multicast	Through UDP: IGMP snooping non-blocking, Layer 2
	Unicast	Through UDP
	Bitrate	Peak: 850Mbps, 4K average: 350Mbps, 1080p average: 250Mbps
Video	Compression Standard	JPEG2K-Like, private stream
	Max Resolution	4K@60Hz (4:4:4)
	HDR 10	Up to 4K@60 4:2:2 12 bit
	EDID	Passthrough, output resolution, predefined default EDID or custom EDID
Audio Formats	LPCM	LPCM up to 7.1/24-bit/192kHz
	Dolby	Dolby Atmos™, Dolby TrueHD, Dolby Digital Plus™, Dolby Digital EX, Dolby Digital 5.1, Dolby Digital 2/0 Surround, Dolby Digital 2/0
	DTS	DTS-HD Master Audio™, DTS-HD, DTS-ES Discrete 6.1, DTS-ES Matrix 6.1, DTS Digital Surround 5.1
Security	HTTPS, 802.1x, OWASP-10, AV Streaming: AES256 encryption	
User Interface	Indicators	LINK, NET and ON LEDs, front panel LCD Display
	Rear Panel	Restart and factory reset rear panel button
	Controls	Embedded web pages, P3K API commands via Ethernet, front panel navigation buttons
Power	PoE+	37V to 57V, maximum power 30W
	Optional power supply	20V DC, 6A Charger PS-2006 is required when using USB-C to charge connected hosts that support USB Power Delivery 2.0, up to 60W.
Environmental Conditions	Operating Temperature	0° to +40°C (32° to 104°F)
	Storage Temperature	-40° to +70°C (-40° to 158°F)
	Humidity	10% to 90%, RHL non-condensing

Regulatory / Standards Compliance	Safety	CE, FCC
	Environmental	RoHs, WEEE, UKCA
Enclosure	Size	Mega Tool Deep
	Material	Aluminum
	Cooling	Convection Ventilation
Dimensions	Net Dimensions (W, D, H)	18.9cm x 17.3cm x 2.76cm (7.4" x 6.8" x 1.1")
	Shipping Dimensions (W, D, H)	31.2cm x 17.9cm x 7.6cm (12.3" x 7.0" x 3.0")
Weight	Net Weight	0.92kg (2.0lbs)
	Shipping Weight	1.14kg (2.5lbs)
Specifications are subject to change without notice at www.kramerav.com		

Protocol 3000

Kramer devices can be operated using Kramer Protocol 3000 commands sent via serial or Ethernet ports.

Understanding Protocol 3000

Protocol 3000 commands are a sequence of ASCII letters, structured according to the following.

- **Command format:**

Prefix	Command Name	Constant (Space)	Parameter(s)	Suffix
#	Command		Parameter	<CR>

- **Feedback format:**

Prefix	Device ID	Constant	Command Name	Parameter(s)	Suffix
~	nn	@	Command	Parameter	<CR><LF>

- **Command parameters** – Multiple parameters must be separated by a comma (,). In addition, multiple parameters can be grouped as a single parameter using brackets ([and]).
- **Parameters attributes** – Parameters may contain multiple attributes. Attributes are indicated with pointy brackets (<...>) and must be separated by a period (.).

The command framing varies according to how you interface with KDS17EN. The following figure displays how the # command is framed using terminal communication software (such as Hercules):

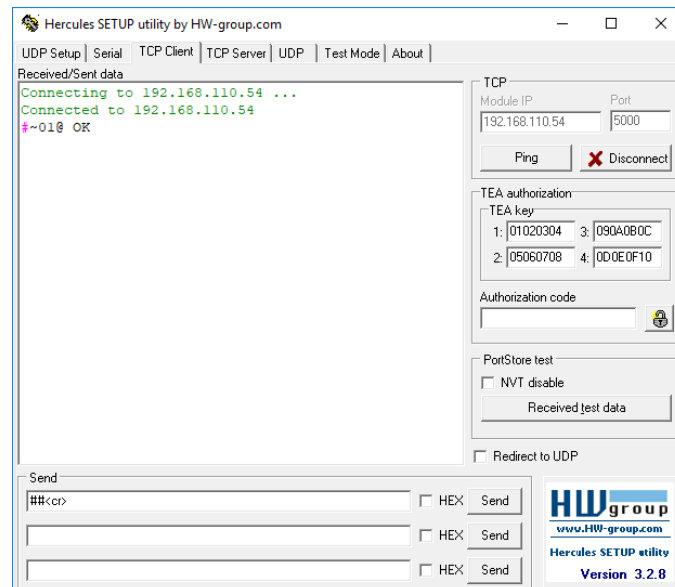

Protocol 3000 Commands

Function	Description	KDS-17 Model	Syntax	Response	Parameters/ Attributes	Example																														
#	Protocol handshaking. NOTE: Validates the Protocol 3000 connection and gets the machine number. Step-in master products use this command to identify the availability of a device.	ALL	#<CR>	-nn@OK<CR><LF>		#<CR>																														
AV-SW-TIMEOUT	Set auto switching timeout.	KDS-17EN-SW2 KDS-17DEC	#AV-SW-TIMEOUT action,time_out<CR>	-nn@AV-SW-TIMEOUT action,time_out<CR><LF>	action – video / audio switching actions 0 – Video signal lost 1 – New video signal detected 2 – Audio signal lost 3 – Audio signal detected 4 – Disable 5V on video output if no input signal detected 5 – Video cable unplugged 6 – Audio cable unplugged 7 – Video signal lost for signal routed as a result of a manual override action time_out - timeout in seconds, for different action it has different valid range: <table border="1"> <tr> <th>Action</th> <th>Range</th> <th>Default</th> </tr> <tr> <td>0</td> <td>5 - 90</td> <td>5</td> </tr> <tr> <td>1</td> <td>0 - 90</td> <td>0</td> </tr> <tr> <td>2</td> <td>5 - 90</td> <td>5</td> </tr> <tr> <td>3</td> <td>0 - 90</td> <td>0</td> </tr> <tr> <td>4 (KDS-17EN-SW2)</td> <td>5 - 60000</td> <td>900</td> </tr> <tr> <td>4 (KDS-17DEC)</td> <td>0 - 90</td> <td>0</td> </tr> <tr> <td>5</td> <td>0 - 90</td> <td>0</td> </tr> <tr> <td>6</td> <td>0 - 90</td> <td>0</td> </tr> <tr> <td>7</td> <td>0 - 90</td> <td>5</td> </tr> </table>	Action	Range	Default	0	5 - 90	5	1	0 - 90	0	2	5 - 90	5	3	0 - 90	0	4 (KDS-17EN-SW2)	5 - 60000	900	4 (KDS-17DEC)	0 - 90	0	5	0 - 90	0	6	0 - 90	0	7	0 - 90	5	Set auto switching "Disable 5V on video output if no input signal detected" to 5 seconds: #AV-SW-TIMEOUT 4.5<CR>
Action	Range	Default																																		
0	5 - 90	5																																		
1	0 - 90	0																																		
2	5 - 90	5																																		
3	0 - 90	0																																		
4 (KDS-17EN-SW2)	5 - 60000	900																																		
4 (KDS-17DEC)	0 - 90	0																																		
5	0 - 90	0																																		
6	0 - 90	0																																		
7	0 - 90	5																																		
AV-SW-TIMEOUT?	Get auto switching timeout.	KDS-17EN-SW2 KDS-17DEC	#AV-SW-TIMEOUT? action<CR>	-nn@AV-SW-TIMEOUT action,time_out<CR><LF>	action – video / audio switching actions 0 – Video signal lost 1 – New video signal detected 2 – Audio signal lost 3 – Audio signal detected 4 – Disable 5V on video output if no input signal detected 5 – Video cable unplugged 6 – Audio cable unplugged 7 – Video signal lost for signal routed as a result of a manual override action time_out - timeout in seconds, for different action it has different valid range: <table border="1"> <tr> <th>Action</th> <th>Range</th> <th>Default</th> </tr> <tr> <td>0</td> <td>5 - 90</td> <td>5</td> </tr> <tr> <td>1</td> <td>0 - 90</td> <td>0</td> </tr> <tr> <td>2</td> <td>5 - 90</td> <td>5</td> </tr> <tr> <td>3</td> <td>0 - 90</td> <td>0</td> </tr> <tr> <td>4 (KDS-17EN-SW2)</td> <td>5 - 60000</td> <td>900</td> </tr> <tr> <td>4 (KDS-17DEC)</td> <td>0 - 90</td> <td>0</td> </tr> <tr> <td>5</td> <td>0 - 90</td> <td>0</td> </tr> <tr> <td>6</td> <td>0 - 90</td> <td>0</td> </tr> <tr> <td>7</td> <td>0 - 90</td> <td>5</td> </tr> </table>	Action	Range	Default	0	5 - 90	5	1	0 - 90	0	2	5 - 90	5	3	0 - 90	0	4 (KDS-17EN-SW2)	5 - 60000	900	4 (KDS-17DEC)	0 - 90	0	5	0 - 90	0	6	0 - 90	0	7	0 - 90	5	Get auto switching "Disable 5V on video output if no input signal detected" value: #AV-SW-TIMEOUT? 4<CR>
Action	Range	Default																																		
0	5 - 90	5																																		
1	0 - 90	0																																		
2	5 - 90	5																																		
3	0 - 90	0																																		
4 (KDS-17EN-SW2)	5 - 60000	900																																		
4 (KDS-17DEC)	0 - 90	0																																		
5	0 - 90	0																																		
6	0 - 90	0																																		
7	0 - 90	5																																		
BUILD-DATE?	Get device build date	ALL	#BUILD-DATE?<CR>	-nn@BUILD-DATE date,time<CR><LF>	date – Format: YYYY/MM/DD where YYYY = Year MM = Month DD = Day time – Format: hh:mm:ss where hh = hours mm = minutes ss = seconds	Get the device build date: #BUILD-DATE?<CR>																														
CD-CONVERT	Set the Color Depth convert mode.	KDS-17EN KDS-17EN-SW2 KDS-17DEC KDS-17DEC-WP	#CD-CONVERT out_index,cd_mode<CR>	-nn@CD-CONVERT out_index,cd_mode<CR><LF>	out_index – Number that indicates the specific output: 1-N (N= the total number of outputs) cd_mode – Index in resolution table: 0 – Follow Output (default) 1 – Force 8 bit	Enable 'force 8 bit' mode for channel 1: #CD-CONVERT 1,1<CR>																														
CD-CONVERT?	Get the Color Depth convert mode.	KDS-17EN KDS-17EN-SW2 KDS-17DEC KDS-17DEC-WP	#CD-CONVERT? out_index<CR>	-nn@CD-CONVERT out_index,cd_mode<CR><LF>	out_index – Number that indicates the specific output: 1-N (N= the total number of outputs) cd_mode – Index in resolution table: 0 – Follow Output (default) 1 – Force 8 bit	Get the color depth convert mode status for channel 1: #CD-CONVERT? 1<CR>																														
CEC-GW-PORT-ACTIVE	Set CEC Gateway mode - Whether CEC commands coming from HDMI stream to LAN	ALL	#CEC-GW-PORT-ACTIVE gw_mode<CR>	-nn@CEC-GW-PORT-ACTIVE gw_mode<CR><LF>	gw_mode: 0 – CEC Passthrough mode between HDMI IN and remote HDMI OUT on Decoders 1 – CEC Gateway mode – command to be sent to HDMI Input. 2 – CEC Gateway mode – command to be sent to HDMI Output. (KDS-17DEC & KDS-17DEC-WP) 3 – CEC Gateway mode – command to be sent to HDMI Loop Through (KDS-17EN, KDS-17EN-SW2) 4 - CEC Passthrough mode between HDMI IN and Local HDMI OUT on KDS-17EN & KDS-17EN-SW2	Set CEC Gateway mode: #CEC-GW-PORT-ACTIVE 1<CR>																														
CEC-GW-PORT-ACTIVE?	Get CEC Gateway mode - Whether CEC commands coming from HDMI stream to LAN	ALL	#CEC-GW-PORT-ACTIVE?<CR>	-nn@CEC-GW-PORT-ACTIVE gw_mode<CR><LF>	gw_mode: 0 – CEC Passthrough mode between HDMI IN and remote HDMI OUT on Decoders 1 – CEC Gateway mode – command to be sent to HDMI Input. 2 – CEC Gateway mode – command to be sent to HDMI Output. (KDS-17DEC & KDS-17DEC-WP) 3 – CEC Gateway mode – command to be sent to HDMI Loop Through (KDS-17EN, KDS-17EN-SW2) 4 - CEC Passthrough mode between HDMI IN and Local HDMI OUT on KDS-17EN & KDS-17EN-SW2	Get CEC Gateway mode: #CEC-GW-PORT-ACTIVE?<CR>																														
CEC-MEMBERS?	Get list of CEC logical addresses.	ALL	#CEC-MEMBERS? port_index<CR>	-nn@CEC-MEMBERS? port_index,<la1>,<la2>...<CR><LF>	Port_index – 1 la – 1 to 15	Get gateway members: #CEC-MEMBERS? 1<CR>																														
CEC-NTFY	Notify about CEC command retrieved from bus. NOTE: Notification is sent to all com ports upon CEC message retrieval from CEC bus	ALL	N/A	-nn@CEC-NTFY port_index,len,<cec_command>...<CR><LF>	port_index – CEC port notifying the command len – 1-16 cec_command – CEC format command (in HEX format, no leading zeros, no '0x' prefix)	Notify about CEC command retrieved from bus: -01@CEC-NTFY 1,2,0F36<CR><LF>																														
CEC-NTFY-MODE	Set CEC notify work mode. NOTE: When it is disabled, all CEC message retrieval from CEC bus will not be reported to connected P3K clients.	ALL	#CEC-NTFY-MODE mode<CR>	-nn@CEC-NTFY-MODE mode<CR><LF>	mode: 1 - Enable notifications (DEFAULT) 0 - Disable notifications	Disable the CEC-NTFY report: #CEC-NTFY-MODE 0<CR>																														
CEC-NTFY-MODE?	Get CEC notify work mode. NOTE: When it is disabled, all CEC message retrieval from CEC bus will not be reported to connected P3K clients.	ALL	#CEC-NTFY-MODE?<CR>	-nn@CEC-NTFY-MODE mode<CR><LF>	mode: 1 - Enable notifications (DEFAULT) 0 - Disable notifications	Get the CEC-NTFY-MODE: #CEC-NTFY-MODE?<CR>																														

Function	Description	KDS-17 Model	Syntax	Response	Parameters/ Attributes	Example
CEC-SND	Send CEC command to port.	ALL	#CEC-SND port_index,sn_id,cmd_name,cec_len,cec_command<CR>	-nn@CEC-SND port_index,sn_id,cmd_name,cec_mode<CR><LF>	port_index – CEC port transmitting the command (1 – number of ports) sn_id – serial number of command for flow control and response commands from device cmd_name – command name cec_len – 1–16 cec_command – CEC format command (in HEX format, no leading zeros, no '0x' prefix) cec_mode – CEC mode 0 – Sent (Only support Sent, other error feedback with common P3K error code)	Send CEC command to port: #CEC-SND 1,1,1,2,E004<CR>
COM-ROUTE-ADD	Add a communication route tunnel connection	ALL	#COM-ROUTE-ADD com_id,port_type,port_id,eth_rep_en,timeout<CR>	-nn@COM-ROUTE-ADD com_id,port_type,port_id,eth_rep_en,timeout<CR><LF>	com_id – Machine dependent (number of ports, only 1 accepted) port_type – TCP/UDP 0 – TCP port_id – port number (5000 to 5999) eth_rep_en – Ethernet Reply 0 – COM port does not send replies to new clients 1 – COM port sends replies to new clients. timeout – Keep alive timeout in seconds (1 to 3600)	Add a communication route tunnel connection: #COM-ROUTE-ADD 1,0,5001,1,1<CR>
COM-ROUTE-REMOVE	Remove a communication route tunnel connection.	ALL	#COM-ROUTE-REMOVE com_id<CR>	-nn@COM-ROUTE-REMOVE com_id<CR><LF>	com_id – Machine dependent (number of ports, only 1 accepted)	Remove a communication route tunnel connection: #COM-ROUTE-REMOVE 1<CR>
COM-ROUTE?	Get communication route tunnel connection state	ALL	#COM-ROUTE? com_id<CR>	-nn@COM-ROUTE com_id,port_type,port_id,eth_rep_en,timeout<CR><LF>	com_id – Machine dependent (number of ports, only 1 accepted), * (get all route tunnels) port_type – TCP/UDP 0 – TCP 1 – UDP port_id – TCP/UDP port number eth_rep_en – Ethernet Reply 0 – COM port does not send replies to new clients 1 – COM port sends replies to new clients. timeout – Keep alive timeout in seconds (1 to 3600)	Get tunneling port routing for all route tunnels: #COM-ROUTE? *<CR>
CS-CONVERT	Set the "force RGB color space" convert mode.	KDS-17DEC KDS-17DEC-WP	#CS-CONVERT out_index,cs_mode<CR>	-nn@CS-CONVERT out_index,cs_mode<CR><LF>	out_index – Number that indicates the specific output: 1-N (N= the total number of outputs) cs_mode – Index in resolution table: 0 – Color space pass (default) 1 – Enable "force RGB color space" convert mode	Enable "force RGB color space" convert mode for channel 1: #CS-CONVERT 1,1<CR>
CS-CONVERT?	Get the "force RGB color space" convert mode.	KDS-17DEC KDS-17DEC-WP	#CS-CONVERT? out_index<CR>	-nn@CS-CONVERT out_index,cs_mode<CR><LF>	out_index – Number that indicates the specific output: 1-N (N= the total number of outputs) cs_mode – Index in resolution table: 0 – Color space pass (default) 1 – Enable "force RGB color space" convert mode	Get the "force RGB color space" convert mode status for channel 1: #CS-CONVERT? 1<CR>
EDID-MODE	Set EDID work mode.	KDS-17EN KDS-17EN-SW2 KDS-17EN-WP	#EDID-MODE Input_id,Mode,Index<CR>	-nn@EDID-MODE Input_id,Mode,Index<CR><LF>	Input_id – 1 Mode: – PASSTHRU (get from decoder) – CUSTOM – DEFAULT Index: Always be 1	Set EDID to custom mode, idx is 1 #EDID-MODE 1,CUSTOM,1<CR>
EDID-MODE?	Get EDID work mode	KDS-17EN KDS-17EN-SW2 KDS-17EN-WP	#EDID-MODE? Input_id<CR>	-nn@EDID-MODE Input_id,Mode, Index<CR><LF>	Input_id – 1 Mode: – PASSTHRU (get from decoder) – CUSTOM – DEFAULT Index: Always be 1	Get EDID Mode #EDID-MODE? 1<CR>
ETH-PORT	Set Ethernet port protocol. NOTE: If the port number you enter is already in use, an error is returned. The port number must be within the following range: 0- (2^16-1).	ALL	#ETH-PORT port_type,port_id<CR>	-nn@ETH-PORT port_type,port_id<CR><LF>	port_type: – TCP – UDP port_id – when port_type = TCP: 5000–5099 when port_type = UDP: 50000–50999	Set the Ethernet port protocol for TCP to port 5000: #ETH-PORT TCP,5000<CR>
ETH-PORT?	Get Ethernet port protocol.	ALL	#ETH-PORT? port_type<CR>	-nn@ETH-PORT port_type,port_id<CR><LF>	port_type: – TCP – UDP port_id – when port_type = TCP: 5000–5099 when port_type = UDP: 50000–50999	Get the Ethernet port protocol for TCP: #ETH-PORT? TCP<CR>
ETH-TUNNEL?	Get an open tunnel parameters.	ALL	#ETH-TUNNEL? tunnel_id<CR>	-nn@ETH-TUNNEL [[tunnel_id,com_id,port_type,port_id,eth_ip,remote_port_id,eth_rep_en,connection_type],...] <CR><LF>	tunnel_id – Tunnel ID number, * (get all open tunnels) com_id – Machine dependent 1 – First COM Port port_type – TCP/UDP 0 – TCP port_id – TCP/UDP port number eth_ip – Client IP address remote_port_id – Remote port number eth_rep_en – Ethernet Reply 0 – COM port does not send replies to new clients 1 – COM port sends replies to new clients connection_type – Connection type 1 – wired connection	Get all open tunnel parameters: #ETH-TUNNEL? *<CR>
FACTORY	Reset device to factory default configuration NOTE: This command deletes all user data from the device. The deletion can take some time. Your device may require powering off and powering on for the changes to take effect.	ALL	#FACTORY<CR>	-nn@FACTORY ok<CR><LF>		Reset the device to factory default configuration: #FACTORY<CR>
GTW-MSG-CLEAR	Clear Control Gateway Messages Counter.	ALL	#GTW-MSG-CLEAR message_type<CR>	-nn@GTW-MSG-CLEAR message_type<CR><LF>	message_type - where 0 = ALL 1 = CEC 2 = IR 3 = RS232	Clear all Control Gateway Messages Counter #GTW-MSG-CLEAR 0<CR>
GTW-MSG-NUM?	Get Control Gateway Messages Counter from the device boot done. Add Recv_Count and Send_Count NOTE: <date> is legacy parameter, for KDS7 always be ignored	ALL	#GTW-MSG-NUM? message_type,date<CR>	-nn@GTW-MSG-NUM message_type,date,recv_counter,send_count<CR><LF>	message_type - where 1 = CEC 2 = IR 3 = RS232 date – Format: DD-MM-YYYY. Recv_counter – counter of receive messages Send_counter – counter of send messages	Get Control Gateway Messages Counter from certain period #GTW-MSG-NUM? 1,01-01-1970<CR>
HDCP-MOD	Set HDCP mode. NOTE: Set HDCP working mode on the device input.	KDS-17EN KDS-17EN-SW2 KDS-17EN-WP KDS-17DEC	#HDCP-MOD in_index,mode<CR>	-nn@HDCP-MOD in_index,mode<CR><LF>	in_index – Number that indicates the specific input: 1-N (N= the total number of inputs) mode – HDCP mode: 0 – HDCP Off 1 – HDCP On	Set the input HDCP-MODE of IN 1 to Off: #HDCP-MOD 1,0<CR>
HDCP-MOD?	Get HDCP mode. NOTE: Get HDCP working mode on the device input.	KDS-17EN KDS-17EN-SW2 KDS-17EN-WP KDS-17DEC	#HDCP-MOD? in_index<CR>	-nn@HDCP-MOD in_index,mode<CR><LF>	in_index – Number that indicates the specific input: 1-N (N= the total number of inputs) mode – HDCP mode: 0 – HDCP Off 1 – HDCP On	Get the input HDCP-MODE of IN 1 HDMI: #HDCP-MOD? 1<CR>
HDCP-OUT	Set output port HDCP mode	KDS-17EN KDS-17EN-SW2 KDS-17DEC KDS-17DEC-WP	#HDCP-OUT in_index,mode<CR>	-nn@HDCP-OUT in_index,mode<CR><LF>	in_index – Number that indicates the specific output: 1-N (N= the total number of inputs) mode – HDCP mode: 0 – HDCP follow input 1 – HDCP follow output (Default)	Set the output HDCP of OUT 1 to follow input: #HDCP-OUT 1,0<CR>
HDCP-OUT?	Get output port HDCP mode	KDS-17EN KDS-17EN-SW2 KDS-17DEC KDS-17DEC-WP	#HDCP-OUT? in_index<CR>	-nn@HDCP-OUT in_index,mode<CR><LF>	in_index – Number that indicates the specific output: 1-N (N= the total number of inputs) mode – HDCP mode: 0 – HDCP follow input 1 – HDCP follow output (Default)	Get the output HDCP of OUT 1: #HDCP-OUT? 1<CR>

Function	Description	KDS-17 Model	Syntax	Response	Parameters/ Attributes	Example
KDS-AES-MOD?	Get AES Mode	ALL	#KDS-AES-MOD?<CR>	-nn@KDS-AES-MOD mode<CR><LF>	mode – AES mode for encoder/decoder, 0 – standard mode 1 – full mode	Get AES mode: #KDS-AES-MOD?<CR>
KDS-CHANNEL-SELECT	Set decoder signal channel id	KDS-17DEC KDS-17DEC-WP	#KDS-CHANNEL-SELECT [signal_type_1,signal_type_2 ...].ch_id<CR>	-nn@KDS-CHANNEL-SELECT [signal_type_1,signal_type_2, ...].ch_id<CR><LF>	signal_type – Signal ID attribute: VIDEO AUDIO IR RS232 USB CEC ch_id – Number that indicates the specific input 0-999. 0 is for cancel the channel select.	Change the decoder to ch id 1 #KDS-CHANNEL-SELECT [video,audio,rs232,ir,usb,cec], 1<CR>
KDS-CHANNEL-SELECT?	Get decoder signal channel id	KDS-17DEC KDS-17DEC-WP	#KDS-CHANNEL-SELECT? signal_type<CR>	-nn@KDS-CHANNEL-SELECT signal_type.ch_id<CR><LF>	signal_type – Signal ID attribute: VIDEO AUDIO IR RS232 USB CEC ch_id – Number that indicates the specific input 0-999. 0 is for cancel the channel select.	Get channel ID #KDS-CHANNEL-SELECT? video<CR>
KDS-DEFINE-CHANNEL	Set Encoder AV channel ID.	KDS-17EN KDS-17EN-SW2 KDS-17EN-WP	#KDS-DEFINE-CHANNEL ch_id<CR>	-nn@KDS-DEFINE-CHANNEL ch_id<CR><LF>	ch_id – Number that indicates the specific input 1-999.	Tune the encoder: #KDS-DEFINE-CHANNEL 1<CR>
KDS-DEFINE-CHANNEL?	Get Encoder AV channel ID.	KDS-17EN KDS-17EN-SW2 KDS-17EN-WP	#KDS-DEFINE-CHANNEL?<CR>	-nn@KDS-DEFINE-CHANNEL ch_id<CR><LF>	ch_id – Number that indicates the specific input 1-999.	Get channel ID: #KDS-DEFINE-CHANNEL?<CR>
KDS-ETH-BRIDGE	Set KDS17 Ethernet bridge mode	ALL	#KDS-ETH-BRIDGE mode,idx,vlanid<CR>	-nn@KDS-ETH-BRIDGE mode,idx,vlanid<CR><LF>	mode: 0 - Disable 1 - Enable idx: interface inde 0 - LAN 1 1 - LAN 2 vlanid: 0-4000	Set bridge mode to LAN2 #KDS-ETH-BRIDGE 1,2,1<CR>
KDS-ETH-BRIDGE?	Get KDS17 Ethernet bridge mode	ALL	#KDS-ETH-BRIDGE?<CR>	-nn@KDS-ETH-BRIDGE mode,idx,vlanid<CR><LF>	mode: 0 - Disable 1 - Enable idx: interface inde 0 - LAN 1 1 - LAN 2 vlanid: 1-4000	Get bridge mode #KDS-ETH-BRIDGE?<CR>
KDS-METHOD	Set unicast / multicast.	ALL	#KDS-METHOD 1<CR>	-nn@KDS-METHOD method<CR><LF>	method – Streaming method 1 Unicast 2 Multicast	Set current streaming method of encoder/decoder: #KDS-METHOD 1<CR>
KDS-METHOD?	Get unicast / multicast.	ALL	#KDS-METHOD?<CR>	-nn@KDS-METHOD method<CR><LF>	method – Streaming method 1 – Unicast 2 – Multicast	Get current streaming method of encoder/decoder: #KDS-METHOD<CR>
KDS-MULTICAST	Set multicast group address and TTL value.	ALL	#KDS-MULTICAST group_ip,ttl<CR>	-nn@KDS-MULTICAST group_ip,ttl<CR><LF>	group_ip – Multicast group IP for KDS-17 is ignored, KDS-17 managed multicast address automatically, so always response 0.0.0.0 ttl - Time to Live of the streamed packets.	Set multicast group address and TTL value #KDS-MULTICAST 0.0.0.0,64<CR>
KDS-MULTICAST-PREFIX	Set prefix of multicast group address.	ALL	#KDS-MULTICAST-PREFIX prefix<CR>	-nn@KDS-MULTICAST-PREFIX prefix<CR><LF>	prefix – Prefix of multicast group IP for KDS7 224-239	Set multicast group address and TTL value #KDS-MULTICAST-PREFIX 224<CR>
KDS-MULTICAST-PREFIX?	Get prefix of multicast group address.	ALL	#KDS-MULTICAST-PREFIX?<CR>	-nn@KDS-MULTICAST-PREFIX prefix<CR><LF>	prefix – Prefix of multicast group IP for KDS7	Get multicast group address and TTL value #KDS-MULTICAST-PREFIX?<CR>
KDS-MULTICAST?	Get multicast group address and TTL value.	ALL	#KDS-MULTICAST?<CR>	-nn@KDS-MULTICAST group_ip,ttl<CR><LF>	group_ip – Multicast group IP for KDS-17 is ignored, KDS-17 managed multicast address automatically, so always response 0.0.0.0 ttl - Time to Live of the streamed packets.	Get multicast group address and TTL value #KDS-MULTICAST?<CR>
KDS-OSD-DISPLAY	Set decoder Display Device Information On/Off	KDS-17DEC KDS-17DEC-WP	#KDS-OSD-DISPLAY mode<CR>	-nn@KDS-OSD-DISPLAY mode<CR><LF>	osd mode 0 – off 1 – on 2 – display now + on	Set OSD Display mode on #KDS-OSD-DISPLAY 1<CR>
KDS-OSD-DISPLAY?	Get decoder Display Device Information status	KDS-17DEC KDS-17DEC-WP	#KDS-OSD-DISPLAY?<CR>	-nn@KDS-OSD-DISPLAY mode<CR><LF>	osd mode 0 – off 1 – on	Get OSD display mode #KDS-OSD-DISPLAY?<CR>
KDS-OSD-HOTKEY	Set decoder OSD hotkey.	KDS-17DEC	#KDS-OSD-HOTKEY mode<CR>	-nn@KDS-OSD-HOTKEY mode<CR><LF>	hotkey mode 0 – CAP 1 – CTL 2 – TAB 3 – SHIFT	Set OSD hotkey to CTL #KDS-OSD-HOTKEY 1<CR>
KDS-OSD-HOTKEY?	Get decoder OSD hotkey.	KDS-17DEC	#KDS-OSD-HOTKEY?<CR>	-nn@KDS-OSD-HOTKEY mode<CR><LF>	hotkey mode 0 – CAP 1 – CTL 2 – TAB 3 – SHIFT	Get OSD hotkey mode #KDS-OSD-HOTKEY?<CR>
KDS-PREVIEW	Set preview parameters. NOTE: When PREVIEW is OFF, other parameters should not be provided	ALL	#KDS-PREVIEW mode,width,height,fps,bw,as,mq<CR>	-nn@KDS-PREVIEW mode,width,height,fps,bw,as,mq<CR>	mode: 0 - OFF 1 - ON width: 0-1280 pixels height: 0-720 pixels fps: 1-60 frames per second bw: 1-50000 Kbps as: 0 - Do not need keep ratio 1 - Keep ratio mq: 60-100	Set preview on with 960x540@10Hz, 8Mbps, keep ratio. #KDS-PREVIEW 1,960,5640,15,8000,0,60<CR>
KDS-PREVIEW?	Get preview parameters. NOTE: When PREVIEW is OFF, other parameters STILL need be responded.	ALL	#KDS-PREVIEW?<CR>	-nn@KDS-PREVIEW mode,width,height,fps,bw,as,mq<CR>	mode: 0 - OFF 1 - ON width: 0-1280 pixels height: 0-720 pixels fps: 1-60 frames per second bw: 1-50000 Kbps as: 0 - Do not need keep ratio 1 - Keep ratio mq: 60-100	Get preview parameters. #KDS-PREVIEW?<CR>
KDS-RATIO?	Get aspect ratio.	ALL	#KDS-RATIO?<CR>	-nn@KDS-RATIO value<CR><LF>	value – Streamer Decoder Aspect Ratio width,height, for example "16:9"	Get Aspect Ratio #KDS-RATIO?<CR>

Function	Description	KDS-17 Model	Syntax	Response	Parameters/ Attributes	Example
KDS-RESOL?	Get actual AV stream resolution.	ALL	#KDS-RESOL? io_mode,io_index,is_native<CR>	-nn@KDS-RESOL? io_mode,io_index,is_native,resolution<CR><LF>	io_mode – Input/Output 0 – Input 1 – Output io_index – Number that indicates the specific input or output port: 1-N (N= the total number of input or output ports) is_native – Native resolution flag 0 – Off 1 – On resolution – Resolution index 0 = No Signal 1 = 640x480p@59.94Hz/60Hz 2 = 720x480p@59.94Hz/60Hz 3 = (Reserved) 4 = 1280x720p@59.94Hz/60Hz 5 = 1920x1080i@59.94Hz/60Hz 6 = 720(1440)x480i@59.94Hz/60Hz 7-15 = (Reserved) 16 = 1920x1080p@59.94Hz/60Hz 17 = 720x576p@50Hz 18 = (Reserved) 19 = 1280x720p@50Hz 20 = 1920x1080i@50Hz 21-30 = (Reserved) 31 = 1920x1080p@50Hz 32 = 1920x1080p@23.97Hz/24Hz 33 = 1920x1080p@25Hz 34 = 1920x1080p@29.97Hz/30Hz 35-38 = (Reserved) 39 = 1920x1080i@50Hz 40-64 = (Reserved) 65 = 800x600p@60Hz 66 = 1024x768@60Hz 67 = 1280x768p@60Hz 68 = 1280x1024p@60Hz 69 = 1600x1200p@60Hz 70 = 1680x1050p@60Hz 71 = 1920x1200@60Hz 72 = 3840x2160p@24Hz 73 = 3840x2160p@25Hz 74 = 3840x2160p@30Hz 75 = 3840x2160p@50Hz 76 = 3840x2160p@60Hz 77-97 = (Reserved) 98 = 4096x2160p@24Hz 99 = 4096x2160p@25Hz 100 = 4096x2160p@30Hz 101 = 4096x2160p@50Hz 102 = 4096x2160p@60Hz 103-1000 = (Reserved) 1000 = 640x350@85Hz 1001 = 640x400p@85Hz 1002 = 720x400p@85Hz 1003 = (Reserved) 1004 = 640x480p@72Hz 1005 = 640x480p@75Hz 1006 = 640x480p@85Hz 1007 = (Reserved) 1008 = (Reserved) 1009 = 800x600p@72Hz 1010 = 800x600p@75Hz 1011 = 800x600p@85Hz 1012 = 848x480p@60Hz 1013 = 1024x768i@43Hz 1014 = (Reserved) 1015 = 1024x768p@70Hz 1016 = 1024x768p@75Hz 1017 = 1024x768p@85Hz 1018 = 1152x864p@75Hz 1019 = (Reserved) 1020 = (Reserved) 1021 = 1280x768p@85Hz 1022 = 1280x800p@60Hz 1023 = 1280x800p@75Hz 1024 = 1280x800p@85Hz 1025 = 1280x800p@120Hz 1026 = 1280x960p@60Hz 1027 = 1280x960p@85Hz 1028 = (Reserved) 1029 = 1280x1024p@75Hz 1030 = 1280x1024p@85Hz 1031 = 1360x768p@60Hz 1032 = 1360x768p@60Hz 1033 = 1400x1050p@60Hz 1034 = 1400x1050p@75Hz 1035 = 1400x1050p@85Hz 1036 = 1440x900p@60Hz 1037 = 1440x900p@75Hz 1038 = 1440x900p@85Hz 1039 = 1600x900p@60Hz 1040 = (Reserved) 1041 = 1600x1200p@65Hz 1042 = (Reserved) 1043 = 1600x1200p@75Hz 1044 = 1600x1200p@85Hz 1045 = (Reserved) 1046 = 1680x1050p@75Hz 1047 = 1680x1050p@85Hz 1048 = 1792x1344p@60Hz 1049 = 1792x1344p@75Hz 1050 = 1856x1392p@60Hz 1051 = 1856x1392p@75Hz 1052 = 1920x1200p@50Hz 1053 = (Reserved) 1054 = 1920x1200p@75Hz 1055 = 1920x1200p@85Hz 1056 = 1920x1440p@60Hz 1057 = 1920x1440p@75Hz 1058 = (Reserved) 1059 = 2048x1152p@60Hz 1060 = 2560x1600p@60Hz 1061 = 2560x1600p@75Hz 1062 = 2560x1600p@80Hz	Get Resolution #KDS-RESOL?<CR>

Function	Description	KDS-17 Model	Syntax	Response	Parameters/ Attributes	Example
KDS-SCALE	Set scaling mode Add res_type.	KDS-17DEC KDS-17DEC-WP	#KDS-SCALE value,res_type<CR>	--nn@KDS-SCALE value,res_type<CR><LF>	value – Streamer Decoder Scaling Mode 0 – Pass Thru 1 – Scaling 2 – Based on EDID res_type[option] – Resolution index 0-3 = (Reserved) 4 = 1280x720p@59.94Hz/60Hz 5-15 = (Reserved) 16 = 1920x1080p@59.94Hz/60Hz 17-30 = (Reserved) 31 = 1920x1080p@50Hz 32-65 = (Reserved) 66 = 1024x768@60Hz 67 = 1280x768p@60Hz 68 = 1280x1024p@60Hz 69 = (Reserved) 70 = 1680x1050@60 71 = 1920x1200@60 72 = (Reserved) 73 = 3840x2160p@25Hz 74 = 3840x2160p@30Hz 75 = 3840x2160p@50Hz 76 = 3840x2160p@60Hz 77-1030 = (Reserved) 1031 = 1360x768p@60Hz 1032-1038 = (Reserved) 1039 = 1600x900p@60Hz 1040-9999 = (Reserved)	Set scale to scaling, resolution is 1080P60 #KDS-SCALE 1,16<CR>
KDS-SCALE?	Get scaling mode Add res_type.	KDS-17DEC KDS-17DEC-WP	#KDS-SCALE?<CR>	--nn@KDS-SCALE value,res_type<CR><LF>	value – Streamer Decoder Scaling Mode 0 – Pass Thru 1 – Scaling 2 – Based on EDID res_type[option] – res_type refer to #KDS-SCALE	Get scaling mode #KDS-SCALE?<CR>
KDS-SLEEP-IMAGE	Set sleep image mode of decoder.	KDS-17DEC KDS-17DEC-WP	#KDS-SLEEP-IMAGE mode<CR>	--nn@KDS-SLEEP-IMAGE mode<CR><LF>	mode – sleep image mode for decoder 0 – Off 1 – On	Stop the Sleep Image: #KDS-SLEEP-IMAGE 0<CR>
KDS-SLEEP-IMAGE?	Get sleep image mode of decoder.	KDS-17DEC KDS-17DEC-WP	#KDS-SLEEP-IMAGE?<CR>	--nn@KDS-SLEEP-IMAGE mode<CR><LF>	mode – sleep image mode for decoder 0 – Off 1 – On	Get the Sleep Image mode: #KDS-SLEEP-IMAGE?<CR>
KDS-VW-MONITOR	Set KDS Video Wall bezel compensation	KDS-17DEC KDS-17DEC-WP	#KDS-VW-MONITOR mon_w,mon_h,b_top,b_bottom b_left,b_right<CR>	--nn@KDS-VW-MONITOR mon_w,mon_h,b_top,b_bottom b_left,b_right<CR><LF>	mon_w – monitor out width, 0–100000 mon_h – monitor height, 0–100000 b_top – bezel top, 0–100000 b_bottom – bezel bottom, 0–10000 b_left – bezel left, 0–10000 b_right – bezel right, 0–10000	Set video wall monitor info #KDS-VW-BESEL 12210,12310,6860,6960<CR>
KDS-VW-MONITOR?	Get KDS Video Wall bezel compensation	KDS-17DEC KDS-17DEC-WP	#KDS-VW-MONITOR?<CR>	--nn@KDS-VW-MONITOR mon_w,mon_h,b_top,b_bottom b_left,b_right<CR><LF>	mon_w – monitor out width, 0–100000 mon_h – monitor height, 0–100000 b_top – bezel top, 0–100000 b_bottom – bezel bottom, 0–10000 b_left – bezel left, 0–10000 b_right – bezel right, 0–10000	Get video wall monitor info #KDS-VW-MONITOR?<CR>
KDS-VW-PATTERN	Set test pattern mode of video wall	KDS-17DEC KDS-17DEC-WP	#KDS-VW-PATTERN mode<CR>	--nn@KDS-VW-PATTERN mode<CR><LF>	mode 0 – OFF (Disable test pattern) 1 – On (Enable test pattern)	Set video wall test pattern on #KDS-VW-PATTERN 1<CR>
KDS-VW-PATTERN?	Get test pattern mode of video wall	KDS-17DEC KDS-17DEC-WP	#KDS-VW-PATTERN?<CR>	--nn@KDS-VW-PATTERN mode<CR><LF>	mode 0 – OFF (Disable test pattern) 1 – On (Enable test pattern)	Get video wall test pattern on #KDS-VW-PATTERN?<CR>
LDFW	Load new firmware file. NOTE: In most devices firmware data is saved to flash memory, but the memory does not update until receiving the "UPGRADE" command and is restarted.	ALL	Step 1: #LDFW size<CR> Step 2: If ready was received, send FIRMWARE_DATA	Response 1: --nn@LDFW size ready<CR><LF> Response 2: --nn@LDFW size ok<CR><LF>	size – Size of firmware data that is sent. firmware_data – HEX or KFW file in protocol packets Using the Packet Protocol Send a command: LDRV, LOAD, IROUT, LDEDID Receive Ready or ERR### If Ready: a. Send a packet, b. Receive OK on the last packet, c. Receive OK for the command. Packet structure: Packet ID (1, 2, 3...) (2 bytes in length) Length (data length + 2 for CRC) – (2 bytes in length) Data (data length -2 bytes) CRC – 2 bytes Response: --nnnn ok<CR><LF> (Where NNNN is the received packet ID in ASCII hex digits.)	Load firmware file. #LDFW<CR>
LOCK-EDID	Lock last read EDID.	KDS-17EN KDS-17EN-SW2 KDS-17EN-WP	#LOCK-EDID in_index,lock_mode<CR>	--nn@LOCK-EDID in_index,lock_mode<CR><LF>	in_index – 1 lock_mode – On/Off 0 – Off unlocks EDID. 1 – On locks EDID.	Lock the last read EDID from the HDMI In 1 input #LOCK-EDID 1,1<CR>
LOCK-EDID?	Get EDID lock state.	KDS-17EN KDS-17EN-SW2 KDS-17EN-WP	#LOCK-EDID? in_index<CR>	--nn@LOCK-EDID in_index,lock_mode<CR><LF>	in_index – 1 lock_mode – On/Off 0 – Off unlocks EDID. 1 – On locks EDID.	Get EDID lock state for Input 1 #LOCK-EDID? 1<CR>
LOCK-FP	Lock the front panel.	KDS-17EN KDS-17EN-SW2 KDS-17DEC	#LOCK-FP lock/unlock<CR>	--nn@LOCK-FP lock/unlock<CR><LF>	Lock/Unlock – On/Off 0 – (Off) Unlocks Front Panel. 1 – (On) Locks Front Panel.	Unlock front panel: #LOCK-FP 0<CR>
LOCK-FP?	Get the front panel lock state.	KDS-17EN KDS-17EN-SW2 KDS-17DEC	#LOCK-FP?<CR>	--nn@LOCK-FP lock/unlock<CR><LF>	Lock/Unlock – On/Off 0 – (Off) Unlocks Front Panel. 1 – (On) Locks Front Panel.	Get the front panel lock state: #LOCK-FP?<CR>
LOG-ACTION	Reset events log.	ALL	#LOG-ACTION action,period<CR>	--nn@LOG-ACTION action,period<CR><LF>	action - One of 1 - Start, start logging 2 - Pause, pause logging but keep log content 3 - Resume, resume the logging 4 - Reset, clear all current logs, keep logging period - Relevant for "start"(be ignored by KDS7 Devices) 1 - Keep current 2 - Daily 3 - Weekly (default)	Reset events log : #LOG-ACTION 4,1<CR>
LOG-ACTION?	Get log state.	ALL	#LOG-ACTION?<CR>	--nn@LOG-ACTION action,period<CR><LF>	action - One of 1 - Start, start logging 2 - Pause, pause logging but keep log content 3 - Resume, resume the logging 4 - Reset, clear all current logs, keep logging period - Relevant for "start"(be ignored by KDS7 Devices) 1 - Keep current 2 - Daily 3 - Weekly (default)	Get log state: #LOG-ACTION?<CR>
LOG-SRV	Set log server.	ALL	#LOG-SRV mode,log_server_ip,log_server_port<CR>	--nn@LOG-SRV mode,log_server_ip,log_server_port<CR><LF>	mode – On/Off 0 – Off 1 – On log_server_ip – Log server IP address log_server_port – Log server port	Set log server with IP address of 128.138.140.44:5050: #LOG-SRV 1,128.138.140.44,5050<CR>
LOG-SRV?	Get log server.	ALL	#LOG-SRV?<CR>	--nn@LOG-SRV mode,log_server_ip,log_server_port<CR><LF>	mode – On/Off 0 – Off 1 – On log_server_ip – Log server IP address log_server_port – Log server port	Get log server: #LOG-SRV?<CR>

Function	Description	KDS-17 Model	Syntax	Response	Parameters/ Attributes	Example
LOGIN	Set protocol permission. NOTE: The permission system works only if security is enabled with the "SECUR" command. LOGIN allows the user to run commands with an End User or Administrator permission level. When the permission system is enabled, LOGIN enables running commands with the User or Administrator permission level. When set, login must be performed upon each connection. It is not mandatory to enable the permission system in order to use the device. In each device, some connections allow logging in to different levels. Some do not work with security at all. Connection may logout after timeout.	ALL	#LOGIN login_level,password<CR>	-nn@LOGIN login_level,password ok<CR><LF>	login_level – Level of permissions required (User or Admin, only 'admin' is acceptable on KDS-17 devices). password – Predefined password (by PASS command). Default password is 'admin'	Set the protocol permission level to Admin (when the password defined in the PASS command is 33333): #LOGIN admin,33333<CR>
LOGIN?	Get current protocol permission level. NOTE: The permission system works only if security is enabled with the "SECUR" command. For devices that support security, LOGIN allows the user to run commands with an End User or Administrator permission level. In each device, some connections allow logging in to different levels. Some do not work with security at all. Connection may logout after timeout.	ALL	#LOGIN?<CR>	-nn@LOGIN login_level<CR><LF>	login_level – Level of permissions required (User or Admin, only 'admin' is acceptable on KDS7 devices)	Get current protocol permission level: #LOGIN?<CR>
LOGOUT	Cancel current permission level. NOTE: Logs out from End User or Administrator permission levels to Not Secure.	ALL	#LOGOUT<CR>	-nn@LOGOUT ok<CR><LF>		#LOGOUT<CR>
LOGOUT-TIMEOUT	Set inactivity auto-logout time.	ALL	#LOGOUT-TIMEOUT time<CR>	-nn@LOGOUT-TIMEOUT time<CR><LF>	time – minutes of logout time 0-60	Set Inactivity auto-logout time to 10 #LOGOUT-TIMEOUT 10<CR>
LOGOUT-TIMEOUT?	Get inactivity auto-logout time.	ALL	#LOGOUT-TIMEOUT?<CR>	-nn@LOGOUT-TIMEOUT time<CR><LF>	time – minutes of logout time 0-60	Get Inactivity auto-logout time #LOGOUT-TIMEOUT?<CR>
MANAGER-ID	Set Manager ID	ALL	#MANAGER-ID token<CR>	-nn@MANAGER-ID token	token - the encrypted token	Set the device be provisioned with one AVoIP Manager #MANAGER-ID VALIDTOKEN<CR>
MANAGER-ID?	Get Manager ID	ALL	#MANAGER-ID?<CR>	-nn@MANAGER-ID timestamp,manager-id	timestamp - provisioning timestamp seconds since 1970 manager-id - a valid UUID, or all 0 for non provision	Set the device be provisioned AVoIP Manager ID #MANAGER-ID?<CR>
MODEL?	Get device model. NOTE: This command identifies equipment connected to KDS-N and notifies of identity changes to the connected equipment. The Matrix saves this data in memory to answer REMOTE-INFO requests.	ALL	#MODEL?<CR>	-nn@MODEL model_name<CR><LF>	model_name – String of up to 24 printable ASCII chars	Get the device model: #MODEL?<CR>
NAME	Set machine or DANTE (DNS) name. NOTE: The machine name is not the same as the model name. The machine name is used to identify a specific machine or a network in use (with DNS feature on).	ALL	#NAME interface_id,host_name<CR>	-nn@NAME interface_id,host_name<CR><LF>	interface_id 0 – machine name host_name – String of up to 64 alpha-numeric chars (can include hyphen, underscore, not at the beginning or end)	Set the machine DNS name of the device to room-442: #NAME 0,room-442<CR>
NAME-RST	Reset machine (DNS) name to factory default. NOTE: Factory default of machine (DNS) name is "KRAMER." + 4 last digits of device serial number.	ALL	#NAMERST<CR>	-nn@NAME-RST OK<CR><LF>		Reset the machine name (S/N last digits are 0102): #NAME-RST<CR>
NAME?	Get machine or DANTE (DNS) name. NOTE: The machine name is not the same as the model name. The machine name is used to identify a specific machine or a network in use (with DNS feature on).	ALL	#NAME? interface_id<CR>	-nn@NAME interface_id,host_name<CR><LF>	interface_id 0 – machine name host_name – String of up to 64 alpha-numeric chars (can include hyphen, not at the beginning or end)	Get the DNS name of the device: #NAME? 0<CR>
NET-SRV-802-1Q	Set a network service 802.1Q configuration.	ALL	#NET-SRV-802-1Q service_id,mode,vlan_id,cos<CR>	-nn@NET-SRV-802-1Q service_id,mode,vlan_id,cos<CR><LF>	service_id – ID of the service: 0 – Control 1 – Stream 2 – Dante 3 – USB Ethernet (Only available for KDS-17EN-WP) mode – enable 802.1Q 0 – off (When mode is Off, vlan_id and cos will be ignored) 1 – on vlan_id – 2-4000 (Optional, when mode is 1, must be provided) cos – 0-7 (Optional, when mode is 1, must be provided)	Set Control service 802.1Q enable with VLAN ID 10, Cos 6 #NET-SRV-802-1Q 0,1,10,6 Set Stream service 802.1Q Off #NET-SRV-802-1Q 0,0
NET-SRV-802-1Q?	Get a network service 802.1Q configuration.	ALL	#NET-SRV-802-1Q? service_id<CR>	-nn@NET-SRV-802-1Q service_id,mode,vlan_id,cos<CR><LF>	service_id – ID of the service: 0 – Control 1 – Stream 2 – Dante 3 – USB Ethernet (Only available for KDS-17EN-WP) mode – enable 802.1Q 0 – Off 1 – On vlan_id – 2-4000 cos – 0-7	Get Control service 802.1Q #NET-SRV-802-1Q? 0

Function	Description	KDS-17 Model	Syntax	Response	Parameters/ Attributes	Example
NET-CONFIG	Set a network configuration. NOTE: For Backward compatibility, the id parameter can be omitted. In this case, the Network ID, by default, is 0, which is the Ethernet control port. NOTE: If the gateway address is not compliant to the subnet mask used for the host IP, the command will return an error. Subnet and gateway compliancy specified by RFC950. NOTE: This set the device to DHCP OFF automatically. NOTE: It will change the IP settings configurations for control service only	ALL	#NET-CONFIG netw_id,net_ip,net_mask,gate way,dns<CR>	-nn@NET-CONFIG netw_id,net_ip,net_mask,gate way,dns<CR><LF>	netw_id – 0,1,... physical interface (will be ignored by KDS-17, and always for Control service) net_ip – Network IP net_mask – Network mask gateway – Network gateway dns - DNS address	Set the device network parameters to IP address 192.168.113.10, net mask 255.255.0.0, and gateway 192.168.0.1: #NET-CONFIG 0,192.168.113.10,255.255.0.0, 192.168.0.1<CR>
NET-CONFIG?	Get a network configuration.	ALL	#NET-CONFIG? netw_id<CR>	-nn@NET-CONFIG netw_id,net_ip,net_mask,gate way,dns<CR><LF>	netw_id – 0,1,... physical interface (will be ignored by KDS-17, and always return Control service) net_ip – Network IP net_mask – Network mask gateway – Network gateway dns - DNS address	Get network configuration: #NET-CONFIG? 0<CR>
NET-SERVICE	Maps applicational service to specific network interface	ALL	#NET-SERVICE service_id,netw_id<CR>	-nn@NET-SERVICE service_id,netw_id<CR><LF>	service_id – ID of the service: 0 – Control 1 – Stream 2 – Dante netw_id – Network ID – 0,1,... physical interface	Set Dante service to LAN-2(eth1) #NET-SERVICE 2,1<CR>
NET-SERVICE?	Get applicational service to specific network interface mapping	ALL	#NET-SERVICE? service_id<CR>	-nn@NET-SERVICE service_id,netw_id<CR><LF>	service_id – ID of the service: 0 – Control 1 – Stream 2 – Dante netw_id – Network ID – 0,1,... physical interface	Get Dante service LAN port #NET-SERVICE? 2<CR>
NET-SRV-CONFIG	Set a network configuration for application services. NOTE: If the gateway address is not compliant to the subnet mask used for the host IP, the command will return an error. Subnet and gateway compliancy specified by RFC950. NOTE: This set the device to DHCP OFF automatically.	ALL	#NET-SRV-CONFIG service_id,net_ip,net_mask,gat eway,dns<CR>	-nn@NET-SRV-CONFIG service_id,net_ip,net_mask,gat eway,dns<CR><LF>	service_id – ID of the service: 0 – Control 1 – Stream 2 – Dante net_ip – Network IP net_mask – Network mask gateway – Network gateway dns - DNS address	Set the device control service network to IP address 192.168.113.10, net mask 255.255.0.0, and gateway 192.168.0.1: #NET-SRV-CONFIG 0,192.168.113.10,255.255.0.0, 192.168.0.1<CR>
NET-SRV-CONFIG?	Get a network configuration for application services.	ALL	#NET-SRV-CONFIG? service_id<CR>	-nn@NET-SRV-CONFIG service_id,net_ip,net_mask,gat eway,dns<CR><LF>	service_id – ID of the service: 0 – Control 1 – Stream 2 – Dante net_ip – Network IP net_mask – Network mask gateway – Network gateway dns - DNS address	Get network configuration for control service: #NET-SRV-CONFIG? 0<CR>
MNG-NET-CONFIG	Set a network configuration for application services.	ALL	#MNG-NET-CONFIG service_id,DHCP,net_IP,net_ mask,gateway,dns,802- 1q_mode,vlan_id,cos,dscp<C R>	-nn@MNG-NET-CONFIG service_id,DHCP,net_IP,net_ mask,gateway,dns,802- 1q_mode,vlan_id,cos,dscp<C R><LF>	service_id – ID of the service: 0 – Control 1 – Stream 2 – Dante dhcp_state – 0 - Use static IP address 1 - Try to use DHCP, net_IP net_mask gateway dns are not relevant for SET command and will be ignored net_IP – Network IP net_mask – Network mask gateway – Network gateway dns - DNS address 802-1q_mode – enable 802.1Q 0 – Off, vlan_id cos dscp are irrelevant for SET command and will be ignored 1 – On vlan_id – 2-4000 cos – 0-7 dscp – 0-63	Set the device control service network: #MNG-NET-CONFIG 0,0,192.168.13.100,255.255.2 55.0,192.168.13.1,8.8.8.8,1,20 7,56<CR>
MNG-NET-CONFIG?	Get a network configuration for application services.	ALL	#MNG-NET-CONFIG? service_id<CR>	-nn@MNG-NET-CONFIG service_id,DHCP,net_IP,net_ mask,gateway,dns,802- 1q_mode,vlan_id,cos,dscp<C R><LF>	service_id – ID of the service: 0 – Control 1 – Stream 2 – Dante dhcp_state – 0 - Use static IP address 1 - Try to use DHCP net_IP – Network IP net_mask – Network mask gateway – Network gateway dns - DNS address 802-1q_mode – enable 802.1Q 0 – Off 1 – On vlan_id – 2-4000 cos – 0-7 dscp – 0-63	Get network configuration for control service: #MNG-NET-CONFIG? 0<CR>
NET-DHCP	Set DHCP mode NOTE: To disable DHCP, the user must configure a static IP address for the device. Connecting Ethernet to devices with DHCP may take more time in some networks. NOTE: For Backward compatibility, the id parameter can be omitted. In this case, the Network ID, by default, is 0, which is the Ethernet control port. NOTE: It will change the IP settings configurations for control service only	ALL	#NET-DHCP netw_id,dhcp_state<CR>	-nn@NET-DHCP netw_id,dhcp_state<CR><LF>	netw_id – 0,1,... physical interface (will be ignored by KDS-17, and always for Control service) dhcp_state – 1 – Try to use DHCP. (If unavailable, use the IP address set by the factory or the net-ip command).	Enable DHCP mode for port 0, if available: #NET-DHCP 0,1<CR>
NET-DHCP?	Get DHCP mode NOTE: For Backward compatibility, the id parameter can be omitted. In this case, the Network ID, by default, is 0, which is the Ethernet control port.	ALL	#NET-DHCP? netw_id<CR>	-nn@NET-DHCP netw_id,dhcp_state<CR><LF>	netw_id – 0,1,... physical interface (will be ignored by KDS-17, and always return Control service) dhcp_state – 1 – Try to use DHCP. (If unavailable, use the IP address set by the factory or the net-ip command).	Get DHCP mode for port 0, if available: #NET-DHCP? 0<CR>

Function	Description	KDS-17 Model	Syntax	Response	Parameters/ Attributes	Example
NET-SRV-DHCP	Set DHCP mode on application services. NOTE: To disable DHCP, the user must configure a static IP address for the device. Connecting Ethernet to devices with DHCP may take more time in some networks.	ALL	#NET-SRV-DHCP service_id,dhcp_state<CR>	--nn@NET-SRV-DHCP service_id,dhcp_state<CR><LF> F>	service_id – ID of the service: 0 – Control 1 – Stream 2 – Dante dhcp_state – 1 – Try to use DHCP. (If unavailable, use the IP address set by the factory or the net-ip command).	Enable DHCP mode for port 0, if available: #NET-SRV-DHCP 0,1<CR>
NET-SRV-DHCP?	Get DHCP mode on application services.	ALL	#NET-SRV-DHCP? service_id<CR>	--nn@NET-SRV-DHCP service_id,dhcp_state<CR><LF> F>	service_id – ID of the service: 0 – Control 1 – Stream 2 – Dante dhcp_state – 1 – Try to use DHCP. (If unavailable, use the IP address set by the factory or the net-ip command).	Get DHCP mode for control service: #NET-SRV-DHCP? 0<CR>
NET-SRV-DSCP	Set a network service DSCP configuration.	ALL	#NET-SRV-DSCP service_id,dscp<CR>	--nn@NET-SRV-DSCP service_id,dscp<CR><LF>	service_id – ID of the service: 0 – Control 1 – Stream 2 – Dante (Can't be changed) dscp – 0-63	Set Control service DSCP as 63 #NET-SRV-DSCP 0,63
NET-SRV-DSCP?	Get a network service DSCP configuration.	ALL	#NET-SRV-DSCP? service_id<CR>	--nn@NET-SRV-DSCP service_id,dscp<CR><LF>	service_id – ID of the service: 0 – Control 1 – Stream 2 – Dante dscp – 0-63	Get Control service DSCP #NET-SRV-DSCP? 0
NET-GATE?	Get gateway IP.	ALL	#NET-GATE?<CR>	--nn@NET-GATE ip_address<CR><LF>	ip_address - Format: xxx.xxx.xxx.xxx	Get gateway IP: #NET-GATE?<CR>
NET-IP?	Get a network IP address. This is an UDP protocol only.	ALL	#NET-IP?<CR>	--nn@NET-IP net_ip<CR><LF>	net_ip – Network IP	Get network ip address: #NET-IP?<CR>
NET-MAC?	Get MAC address.	ALL	#NET-MAC? netw_id<CR>	--nn@NET-MAC netw_id,mac_address<CR><LF> F>	netw_id – Network ID – ID of the Ethernet port: 0 – LAN-1 1 – LAN-2 mac_address – Unique MAC address. Format: XX-XX-XX-XX-XX-XX where X is hex digit	#NET-MAC?<CR>
NET-MASK?	Get subnet mask.	ALL	#NET-MASK?<CR>	--nn@NET-MASK net_mask<CR><LF>	net_mask - Format: xxx.xxx.xxx.xxx	Get subnet mask: #NET-MASK?<CR>
NET-STAT?	Get net connection list of this machine. NOTE: The response is returned in one line and terminated with<CR><LF>. The response format lists signal IDs separated by commas. This is an Extended Protocol 3000 command.	ALL	#NET-STAT?<CR>	--nn@NET-STAT [<port_type>:<port_index>,<client_ip>:<client_port>],state ...<CR><LF>	port_type – TCP/UDP 0 – TCP 1 – UDP port_index – Device port client_ip – Dot-separated representation of the IP address client_port – Client port state – listen or established	Get net connection list of this machine: #NET-STATE?<CR> -01@NET-STAT [(TCP:80,0.0.0.0:0),LISTEN],[(TCP:5000,0.0.0.0:0),LISTEN], [(TCP:80,192.168.114.3:52400), ESTABLISHED],[TCP:5000, 192.168.1.100:51647], ESTABLISHED]<CR><LF>
PASS	Set password for login level. The default password is "admin".	ALL	#PASS login_level,password<CR>	--nn@PASS login_level,password<CR><LF> >	login_level – Level of login to set (admin support only). password – Password for the login_level. 8 to 24 characters (letters, numbers, and symbols without spaces or commas), at least including one number, one symbols without spaces or commas, one uppercase letter and one lowercase letter.	Set the password for the admin protocol permission level to 33333: #PASS admin,33333<CR>
PASS?	Get password for login level. The default password is "admin".	ALL	#PASS? login_level<CR>	--nn@PASS login_level,password<CR><LF> >	login_level – Level of login to set (End User or Administrator). password – Password for the login_level.	Get the password for the admin protocol permission level: #PASS? admin<CR>
PORT-DIRECTION	Set port direction as input or output.	ALL	#PORT-DIRECTION <direction_type>:<port_format>:<port_index>:<signal_type>,<direction><CR>	--nn@PORT-DIRECTION <direction_type>:<port_format>:<port_index>:<signal_type>,<direction><CR><LF>	The following attributes comprise the signal ID: <direction_type> – Direction of the port: IN – Input OUT – Output BOTH – Bi-directional <port_format> – Type of signal on the port: ANALOG_AUDIO IR <port_index> – The port number as printed on the front or rear panel <signal_type> – Signal ID attribute: AUDIO IR <direction> – Direction of the port: IN – Input OUT – Output	Set audio analog port direction as input #PORT-DIRECTION both.analog.1.audio.IN<CR>
PORT-DIRECTION?	Get port direction.	ALL	#PORT-DIRECTION? <direction_type>:<port_format>:<port_index>:<signal_type><CR>	--nn@PORT-DIRECTION <direction_type>:<port_format>:<port_index>:<signal_type>,<direction><CR><LF>	The following attributes comprise the signal ID: <direction_type> – Direction of the port: IN – Input OUT – Output BOTH – Bi-directional <port_format> – Type of signal on the port: ANALOG_AUDIO IR <port_index> – The port number as printed on the front or rear panel <signal_type> – Signal ID attribute: AUDIO IR <direction> – Direction of the port: IN – Input OUT – Output	Get audio analog port direction #PORT-DIRECTION? both.analog.1.audio<CR>
PORTS-LIST?	Get the port list of this machine. NOTE: The response is returned in one line and terminated with<CR><LF>. The response format lists port IDs separated by commas. This is an Extended Protocol 3000 command.	ALL	#PORTS-LIST?<CR>	--nn@PORTS-LIST [<direction_type>:<port_format>:<port_index>,...,]<CR><LF>	The following attributes comprise the port ID: <direction_type> – Direction of the port: IN OUT BOTH <port_format> – Type of signal on the port: HDMI ANALOG_AUDIO RS-232 IR USB_A USB_B USB_C STREAM <port_index> – The port number as printed on the front or rear panel	Get the ports list: #PORTS-LIST?<CR>
PROT-VER?	Get device protocol version.	ALL	#PROT-VER?<CR>	--nn@PROT-VER 3000:version<CR><LF>	3000: - Prefix version - XX.XX where X is a decimal digit	Get the device protocol version: #PROT-VER?<CR>
RESET	Reset device NOTE: To avoid locking the port due to a USB bug in Windows, disconnect USB connections immediately after running this command. If the port was locked, disconnect and reconnect the cable to reopen the port.	ALL	#RESET<CR>	--nn@RESET ok<CR><LF>		Reset the device: #RESET<CR>
SECUR	Start/stop P3K communication security. NOTE: The permission system works only if security is enabled with the "SECUR" command.	ALL	#SECUR security_state<CR>	--nn@SECUR security_state<CR><LF>	security_state – Security state 0 – OFF (disables security) 1 – ON (enables security)	Enable the permission system: #SECUR 1<CR>
SECUR?	Get P3K security state.	ALL	#SECUR?<CR>	--nn@SECUR security_state<CR><LF>	security_state – Security state 0 – OFF (disables security) 1 – ON (enables security)	Get security state: #SECUR?<CR>

Function	Description	KDS-17 Model	Syntax	Response	Parameters/ Attributes	Example
SIGNALS-LIST?	Get signal ID list of this machine. NOTE: The response is returned in one line and terminated with<CR><LF>. The response format lists signal IDs separated by commas. This is an Extended Protocol 3000 command.	ALL	#SIGNALS-LIST?<CR><LF>	-nn@SIGNALS-LIST {<direction_type>,<port_format>,<port_label>,<signal_type>,<index>},<CR><LF>	The following attributes comprise the signal ID: <direction_type> – Direction of the port: IN – Input OUT – Output BOTH – Bi-directional (e.g. for RS-232) <port_format> – Type of signal on the port: HDMI ANALOG_AUDIO RS-232 IR USB_A USB_B USB_C STREAM <port_index> – The port number as printed on the front or rear panel <signal_type> – Signal ID attribute: VIDEO AUDIO RS232 IR USB <index> – Indicates a specific channel number when there are multiple channels of the same type	Get signal ID list: #SIGNALS-LIST?<CR>
SN?	Get device serial number.	ALL	#SN?<CR>	-nn@SN serial_num<CR><LF>	serial_num – 14 decimal digits, factory assigned	Get the device serial number: #SN?<CR>
TIME	Set device time and date. NOTE: The year must be 4 digits. The device does not validate the day of week from the date. Time format - 24 hours. Date format - Day, Month, Year.	ALL	#TIME day_of_week,date,data<CR>	-nn@TIME day_of_week,date,data<CR><LF>	day_of_week – One of {SUN,MON,TUE,WED,THU,FRI,SAT} date – Format: DD-MM-YYYY where YYYY = Year MM = Month DD = Day data – Format: hh:mm:ss where hh = hours mm = minutes ss = seconds	Set device time and date to December 5, 2018 at 2:30pm: #TIME mon,05-12-2018,14:30:00<CR>
TIME-SRV	Set time server. NOTE: This command is needed for setting UDP timeout for the current client list.	ALL	#TIMESRV mode,time_server_ip,sync_hour<CR>	-nn@TIMESRV mode,time_server_ip,sync_hour,server_status<CR><LF>	mode – On/Off 0 – Off 1 – On time_server_ip – Time server IP address sync_hour – Hour in day for time server sync server_status – On/Off	Set time server with IP address of 128.138.140.44 to ON: #TIME-SRV 1,128.138.140.44,0<CR>
TIME-SRV?	Get time server. NOTE: This command is needed for setting UDP timeout for the current client list.	ALL	#TIMESRV?<CR>	-nn@TIMESRV mode,time_server_ip,sync_hour,server_status<CR><LF>	mode – On/Off 0 – Off 1 – On time_server_ip – Time server IP address sync_hour – Hour in day for time server sync server_status – On/Off	Get time server: #TIMESRV?<CR>
TIME-ZONE	Set the device time zone.	ALL	#TIME-ZONE timezone_str<CR>	-nn@TIME-ZONE timezone_str<CR><LF>	timezone_str – A string that identifies the relevant time zone.	Set time zone to London, England: #TIME-ZONE europe/london<CR>
TIME-ZONE?	Get the device time zone.	ALL	#TIME-ZONE?<CR>	-nn@TIME-ZONE timezone_str<CR><LF>	timezone_str – A string that identifies the relevant time zone.	Get the device time zone: #TIME-ZONE?<CR>
TIME?	Get device time and date. NOTE: The year must be 4 digits. The device does not validate the day of week from the date. Time format - 24 hours. Date format - Day, Month, Year.	ALL	#TIME?<CR>	-nn@TIME day_of_week,date,data<CR><LF>	day_of_week – One of {SUN,MON,TUE,WED,THU,FRI,SAT} date – Format: YYYY/MM/DD where YYYY = Year MM = Month DD = Day data – Format: hh:mm:ss where hh = hours mm = minutes ss = seconds	Get device time and date: #TIME?<CR>
UART	Set com port configuration.	ALL	#UART com_id,baud_rate,data_bits,parity,stop_bits_mode,serial_type<CR>	-nn@UART com_id,baud_rate,data_bits,parity,stop_bits_mode,serial_type<CR><LF>	com_id – 1 to n (machine dependent) baud_rate – 1200 - 115200 data_bits – 5-8 parity – Parity Type 0 – No 1 – Odd 2 – Even stop_bits_mode – 1/2 serial_type – 232/ 0 – 232	Set baud rate to 9600, 8 data bits, parity to none and stop bit to 1: #UART 1,9600,8,0,1,0<CR>
UART?	Get com port configuration.	ALL	#UART? com_id<CR>	-nn@UART com_id,baud_rate,data_bits,parity,stop_bits_mode,serial_type<CR><LF>	com_id – 1 to n (machine dependent) baud_rate – 1200 - 115200 data_bits – 5-8 parity – Parity Type 0 – No 1 – Odd 2 – Even stop_bits_mode – 1/2 serial_type – 232 0 – 232	Get baud rate: #UART? 1<CR>
UPG-TIME?	Get firmware version last upgrade date/time	ALL	#UPG-TIME?<CR>	-nn@UPG-TIME date,data<CR><LF>	date – Format: DD-MM-YYYY. data – Format: hh:mm:ss where	Get last upgrade date/time #UPG-TIME?<CR>
UPGRADE	Perform firmware upgrade. NOTE: Not necessary for some devices. Firmware usually uploads to a device via a command like LDFW. Reset the device to complete the process.	ALL	#UPGRADE<CR>	-nn@UPGRADE ok<CR><LF>		Perform firmware upgrade: #UPGRADE<CR>
USBC-LANE-CFG	Set USB-C LANE working mode	KDS-17EN-SW2 KDS-17EN-WP	#USBC-LANE-CFG port_id,mode<CR>	-nn@USBC-LANE-CFG port_id,mode<CR><LF>	port_id – USB-C port Id for multi-port devices support (1...N) mode – USB-C working mode: 1 – 2 Video (DP) Lanes + USB 3.x 2 – 4 Video (DP) Lanes + USB 2.0	Set USB-C port 1 as 2 Video Lanes + USB 3.x #USBC-LANE-CFG 1,1<CR>
USBC-LANE-CFG?	Get USB-C LANE working mode	KDS-17EN-SW2 KDS-17EN-WP	#USBC-LANE-CFG? port_id<CR>	-nn@USBC-LANE-CFG port_id,mode<CR><LF>	port_id – USB-C port Id for multi-port devices support (1...N) mode – USB-C working mode: 1 – 2 Video (DP) Lanes + USB 3.x 2 – 4 Video (DP) Lanes + USB 2.0	Get USB-C port 1 as 2 Video Lanes + USB 3.x #USBC-LANE-CFG? 1<CR>
VERSION?	Get firmware version number.	ALL	#VERSION?<CR>	-nn@VERSION firmware_version<CR><LF>	firmware_version – XX.XX.XXXX where the digit groups are: major.minor.build version	Get the device firmware version number: #VERSION?<CR>
VIDEO-WALL-SETUP	Define device video wall relative position and video alignment. NOTE: MUST setup with #VIEW-MOD 15" or #VIEW-MOD 16" to video wall mode firstly	KDS-17DEC KDS-17DEC-WP	#VIDEO-WALL-SETUP out_id,rotation<CR>	-nn@VIDEO-WALL-SETUP out_id,rotation<CR><LF>	out_id – Number of output (1-256), =1 when view mode is 16 rotation – Rotation degrees in clockwise 0 – 0 degrees 1 – 90 degrees 2 – 180 degrees 3 – 270 degrees 4 – vertical flip 5 – horizontal flip	Set video alignment: #VIDEO-WALL-SETUP 10,1<CR>
VIDEO-WALL-SETUP?	Get device video wall relative position and video alignment.	KDS-17DEC KDS-17DEC-WP	#VIDEO-WALL-SETUP?<CR>	-nn@VIDEO-WALL-SETUP out_id,rotation<CR><LF>	out_id – Number of output (1-256), =1 when view mode is 16 rotation – Rotation degrees in clockwise 0 – 0 degrees 1 – 90 degrees 2 – 180 degrees 3 – 270 degrees 4 – vertical flip 5 – horizontal flip	Get video alignment: #VIDEO-WALL-SETUP?<CR>

Function	Description	KDS-17 Model	Syntax	Response	Parameters/ Attributes	Example
VIEW-MOD	Set view mode. Use "VIEW-MOD 15,1,1" for disabling video wall.	KDS-17DEC KDS-17DEC-WP	#VIEW-MOD mode,vw_hsize,vw_vsize<CR> > or #VIEWMOD mode,x1,y1,x2,y2<CR>	-nn@VIEW-MOD mode,vw_hsize,vw_vsize<CR><LF>	mode – View Modes 15 – Video wall 16 – Mosaic style video wall vw_hsize – video wall horrible size, only required when mode is 15 vw_vsize – video wall vertical size, only required when mode is 15 (x1, y1) – will be the virtual coordinates of top left position, only required when mode is 16 (x2, y2) – will be the virtual coordinates of bottom right position, only required when mode is 16 the range for x1, y1, x2, y2 is: 0 – 10000.	Set view mode to a 2x2 grid video wall: #VIEW-MOD 15,2,2<CR> Set view mode to a mosaic style video wall for show 1/4 top left image: #VIEW-MOD 16,0,0,5000,5000<CR>
VIEW-MOD?	Get view mode.	KDS-17DEC KDS-17DEC-WP	#VIEW-MOD?<CR>	-nn@VIEW-MOD mode,vw_hsize,vw_vsize<CR><LF> or -nn@VIEWMOD mode,x1,y1,x2,y2<CR><LF>	mode – View Modes 15 – Video wall vw_hsize – video wall horrible size, only required when mode is 15 vw_vsize – video wall vertical size, only required when mode is 15 (x1, y1) – will be the virtual coordinates of top left position, only required when mode is 16 (x2, y2) – will be the virtual coordinates of bottom right position, only required when mode is 16 the range for x1, y1, x2, y2 is: 0 – 10000.	Get view mode: #VIEW-MOD?<CR>
WND-STRETCH	Set video wall stretch type	KDS-17DEC KDS-17DEC-WP	#WND-STRETCH out_index,mode<CR>	-nn@WND-STRETCH out_index,mode<CR><LF>	out_index – Number that indicates the specific output 1-256: 1-N (N= the total number of outputs) mode - Stretch mode: 0 - Stretch 1 - Crop 2 - Best Fit	Set Video Wall Stretch Type is Fit In: #WND-STRETCH 1,0<CR>
WND-STRETCH?	Get video wall stretch type	KDS-17DEC KDS-17DEC-WP	#WND-STRETCH? out_index<CR>	-nn@WND-STRETCH out_index,mode<CR><LF>	out_index – Number that indicates the specific output 1-256: 1-N (N= the total number of outputs) mode - Stretch mode: 0 - Stretch 1 - Crop 2 - Best Fit	Get Video Wall Stretch Type: #WND-STRETCH? 1<CR>
X-AUD-DESC?	Get audio signal info NOTE: + This is an Extended Protocol 3000 command. + On KDS7 only support activated port	ALL	#X-AUD-DESC? <direction_type>.<port_format>.<port_index><CR>	-nn@X-AUD-DESC? <direction_type>.<port_format>.<port_index>.<signal_type>.<index>.<ch_tot,samp_rate,aud_format><CR><LF>	The following attributes comprise the signal ID: 1-N (N= the total number of outputs) <direction_type> – Direction of the port: IN – Input OUT – Output BOTH – Bi-directional (e.g. for RS-232) <port_format> – Type of signal on the port: HDMI ANALOG_AUDIO STREAM DANTE USB_C – Only available on KDS-17EN-WP <port_index> – The port number as printed on the front or rear panel <signal_type> – Signal ID attribute: AUDIO <index> – Indicates a specific channel number when there are multiple ch_tot – Total number of channels samp_rate – Sample rate aud_format – Audio Format: LPCM – Linear Pulse Code Modulation audio Non-LPCM – None Linear Pulse Code Modulation audio, like Dolby Digital, DTS, etc. HBR – High Bitrate Audio, like Dolby TrueHD, DTS HD Master Audio.	Get the audio signal info: #X-AUD-DESC? out.hdmi.1<CR>
X-AUD-LVL	Set audio level of a specific signal. NOTE: This is an Extended Protocol 3000 command.	ALL	#X-AUD-LVL <direction_type>.<port_format>.<port_index>.<signal_type>.<index>.<audio_level><CR>	-nn@X-AUD-LVL <direction_type>.<port_format>.<port_index>.<signal_type>.<index>.<audio_level><CR><LF>	The following attributes comprise the signal ID: <direction_type> – Direction of the port: OUT – Output <port_format> – Type of signal on the port: ANALOG_AUDIO <port_index> – The port number as printed on the front or rear panel <signal_type> – Signal ID attribute: AUDIO <index> – Indicates a specific channel number when there are multiple channels of the same type audio_level – Audio level (range between 0 to 100)	Set the audio level of a specific signal to 80: #X-AUD-LVL in.analog_audio.1.audio.1,80<CR>
X-AUD-LVL?	Get audio level of a specific signal. NOTE: This is an Extended Protocol 3000 command.	ALL	#X-AUD-LVL? <direction_type>.<port_format>.<port_index>.<signal_type>.<index><CR>	-nn@X-AUD-LVL <direction_type>.<port_format>.<port_index>.<signal_type>.<index>.<audio_level><CR><LF>	The following attributes comprise the signal ID: <direction_type> – Direction of the port: OUT – Output <port_format> – Type of signal on the port: ANALOG_AUDIO <port_index> – The port number as printed on the front or rear panel <signal_type> – Signal ID attribute: AUDIO <index> – Indicates a specific channel number when there are multiple channels of the same type audio_level – Audio level (range between 0 to 100)	Get the audio level of a specific signal: #X-AUD-LVL? out.analog_audio.1.audio.1<CR>
X-AV-SW-MODE	Set auto-switch mode per output. NOTE: This is an Extended Protocol 3000 command.	KDS-17EN KDS-17DEC KDS-17EN-SW2 KDS-17EN-WP	#X-AV-SW-MODE <direction_type>.<port_format>.<port_index>.<signal_type>.<index>.<connection_mode><CR>>	-nn@X-AV-SW-MODE <direction_type>.<port_format>.<port_index>.<signal_type>.<index>.<connection_mode><CR><LF>	The following attributes comprise the signal ID: <direction_type> – Direction of the port: OUT – Output <port_format> – Type of signal on the port: HDMI ANALOG_AUDIO STREAM <port_index> – The port number as printed on the front or rear panel <signal_type> – Signal ID attribute: VIDEO AUDIO <index> – Indicates a specific channel number when there are multiple channels of the same type connection_mode – Connection mode 0 – manual 1 – priority 2 – last connected	Set auto switch mode for HDMI OUT 1 (last connected): #X-AV-SW-MODE out.hdmi.1.video.1,2<CR>

Result and Error Codes

Syntax

In case of an error, the device responds with an error message. The error message syntax:

- `~NN@ERR XXX<CR><LF>` – when general error, no specific command
- `~NN@CMD ERR XXX<CR><LF>` – for specific command
- **NN** – machine number of device, default = 01
- **XXX** – error code

Error Codes

Error Name	Error Code	Description
P3K_NO_ERROR	0	No error
ERR_PROTOCOL_SYNTAX	1	Protocol syntax
ERR_COMMAND_NOT_AVAILABLE	2	Command not available
ERR_PARAMETER_OUT_OF_RANGE	3	Parameter out of range
ERR_UNAUTHORIZED_ACCESS	4	Unauthorized access
ERR_INTERNAL_FW_ERROR	5	Internal FW error
ERR_BUSY	6	Protocol busy
ERR_WRONG_CRC	7	Wrong CRC
ERR_TIMEDOUT	8	Timeout
ERR_RESERVED	9	(Reserved)
ERR_FW_NOT_ENOUGH_SPACE	10	Not enough space for data (firmware, FPGA...)
ERR_FS_NOT_ENOUGH_SPACE	11	Not enough space – file system
ERR_FS_FILE_NOT_EXISTS	12	File does not exist
ERR_FS_FILE_CANT_CREATED	13	File can't be created
ERR_FS_FILE_CANT_OPEN	14	File can't open
ERR_FEATURE_NOT_SUPPORTED	15	Feature is not supported
ERR_RESERVED_2	16	(Reserved)
ERR_RESERVED_3	17	(Reserved)
ERR_RESERVED_4	18	(Reserved)
ERR_RESERVED_5	19	(Reserved)
ERR_RESERVED_6	20	(Reserved)
ERR_PACKET_CRC	21	Packet CRC error
ERR_PACKET_MISSED	22	Packet number isn't expected (missing packet)
ERR_PACKET_SIZE	23	Packet size is wrong
ERR_RESERVED_7	24	(Reserved)
ERR_RESERVED_8	25	(Reserved)
ERR_RESERVED_9	26	(Reserved)
ERR_RESERVED_10	27	(Reserved)
ERR_RESERVED_11	28	(Reserved)
ERR_RESERVED_12	29	(Reserved)
ERR_EDID_CORRUPTED	30	EDID corrupted
ERR_NON_LISTED	31	Device specific errors
ERR_SAME_CRC	32	File has the same CRC – not changed
ERR_WRONG_MODE	33	Wrong operation mode
ERR_NOT_CONFIGURED	34	Device/chip was not initialized

The warranty obligations of Kramer Electronics Inc. ("Kramer Electronics") for this product are limited to the terms set forth below:

What is Covered

This limited warranty covers defects in materials and workmanship in this product.

What is Not Covered

This limited warranty does not cover any damage, deterioration or malfunction resulting from any alteration, modification, improper or unreasonable use or maintenance, misuse, abuse, accident, neglect, exposure to excess moisture, fire, improper packing and shipping (such claims must be presented to the carrier), lightning, power surges, or other acts of nature. This limited warranty does not cover any damage, deterioration or malfunction resulting from the installation or removal of this product from any installation, any unauthorized tampering with this product, any repairs attempted by anyone unauthorized by Kramer Electronics to make such repairs, or any other cause which does not relate directly to a defect in materials and/or workmanship of this product. This limited warranty does not cover cartons, equipment enclosures, cables or accessories used in conjunction with this product.

Without limiting any other exclusion herein, Kramer Electronics does not warrant that the product covered hereby, including, without limitation, the technology and/or integrated circuit(s) included in the product, will not become obsolete or that such items are or will remain compatible with any other product or technology with which the product may be used.

How Long this Coverage Lasts

The standard limited warranty for Kramer products is seven (7) years from the date of original purchase, with the following exceptions:

1. All Kramer VIA hardware products are covered by a standard three (3) year warranty for the VIA hardware and a standard three (3) year warranty for firmware and software updates; all Kramer VIA accessories, adapters, tags, and dongles are covered by a standard one (1) year warranty.
2. Kramer fiber optic cables, adapter-size fiber optic extenders, pluggable optical modules, active cables, cable retractors, ring mounted adapters, portable power chargers, Kramer speakers, and Kramer touch panels are covered by a standard one (1) year warranty. Kramer 7 inch touch panels purchased on or after April 1st, 2020 are covered by a standard two (2) year warranty.
3. All Kramer Calibre products, all Kramer Minicom digital signage products, all HighSecLabs products, all streaming, and all wireless products are covered by a standard three (3) year warranty.
4. All Sierra Video MultiViewers are covered by a standard five (5) year warranty.
5. Sierra switchers & control panels are covered by a standard seven (7) year warranty (excluding power supplies and fans that are covered for three (3) years).
6. K-Touch software is covered by a standard one (1) year warranty for software updates.
7. All Kramer passive cables are covered by a lifetime warranty.

Who is Covered

Only the original purchaser of this product is covered under this limited warranty. This limited warranty is not transferable to subsequent purchasers or owners of this product.

What Kramer Electronics Will Do

Kramer Electronics will, at its sole option, provide one of the following three remedies to whatever extent it shall deem necessary to satisfy a proper claim under this limited warranty:

1. Elect to repair or facilitate the repair of any defective parts within a reasonable period of time, free of any charge for the necessary parts and labor to complete the repair and restore this product to its proper operating condition. Kramer Electronics will also pay the shipping costs necessary to return this product once the repair is complete.
2. Replace this product with a direct replacement or with a similar product deemed by Kramer Electronics to perform substantially the same function as the original product. If a direct or similar replacement product is supplied, the original product's end warranty date remains unchanged and is transferred to the replacement product.
3. Issue a refund of the original purchase price less depreciation to be determined based on the age of the product at the time remedy is sought under this limited warranty.

What Kramer Electronics Will Not Do Under This Limited Warranty

If this product is returned to Kramer Electronics or the authorized dealer from which it was purchased or any other party authorized to repair Kramer Electronics products, this product must be insured during shipment, with the insurance and shipping charges prepaid by you. If this product is returned uninsured, you assume all risks of loss or damage during shipment. Kramer Electronics will not be responsible for any costs related to the removal or re-installation of this product from or into any installation. Kramer Electronics will not be responsible for any costs related to any setting up this product, any adjustment of user controls or any programming required for a specific installation of this product.

How to Obtain a Remedy Under This Limited Warranty

To obtain a remedy under this limited warranty, you must contact either the authorized Kramer Electronics reseller from whom you purchased this product or the Kramer Electronics office nearest you. For a list of authorized Kramer Electronics resellers and/or Kramer Electronics authorized service providers, visit our web site at www.kramerav.com or contact the Kramer Electronics office nearest you.

In order to pursue any remedy under this limited warranty, you must possess an original, dated receipt as proof of purchase from an authorized Kramer Electronics reseller. If this product is returned under this limited warranty, a return authorization number, obtained from Kramer Electronics, will be required (RMA number). You may also be directed to an authorized reseller or a person authorized by Kramer Electronics to repair the product.

If it is decided that this product should be returned directly to Kramer Electronics, this product should be properly packed, preferably in the original carton, for shipping. Cartons not bearing a return authorization number will be refused.

Limitation of Liability

THE MAXIMUM LIABILITY OF KRAMER ELECTRONICS UNDER THIS LIMITED WARRANTY SHALL NOT EXCEED THE ACTUAL PURCHASE PRICE PAID FOR THE PRODUCT. TO THE MAXIMUM EXTENT PERMITTED BY LAW, KRAMER ELECTRONICS IS NOT RESPONSIBLE FOR DIRECT, SPECIAL, INCIDENTAL OR CONSEQUENTIAL DAMAGES RESULTING FROM ANY BREACH OF WARRANTY OR CONDITION, OR UNDER ANY OTHER LEGAL THEORY. Some countries, districts or states do not allow the exclusion or limitation of relief, special, incidental, consequential or indirect damages, or the limitation of liability to specified amounts, so the above limitations or exclusions may not apply to you.

Exclusive Remedy

TO THE MAXIMUM EXTENT PERMITTED BY LAW, THIS LIMITED WARRANTY AND THE REMEDIES SET FORTH ABOVE ARE EXCLUSIVE AND IN LIEU OF ALL OTHER WARRANTIES, REMEDIES AND CONDITIONS, WHETHER ORAL OR WRITTEN, EXPRESS OR IMPLIED. TO THE MAXIMUM EXTENT PERMITTED BY LAW, KRAMER ELECTRONICS SPECIFICALLY DISCLAIMS ANY AND ALL IMPLIED WARRANTIES, INCLUDING, WITHOUT LIMITATION, WARRANTIES OF MERCHANTABILITY AND FITNESS FOR A PARTICULAR PURPOSE. IF KRAMER ELECTRONICS CANNOT LAWFULLY DISCLAIM OR EXCLUDE IMPLIED WARRANTIES UNDER APPLICABLE LAW, THEN ALL IMPLIED WARRANTIES COVERING THIS PRODUCT, INCLUDING WARRANTIES OF MERCHANTABILITY AND FITNESS FOR A PARTICULAR PURPOSE, SHALL APPLY TO THIS PRODUCT AS PROVIDED UNDER APPLICABLE LAW. IF ANY PRODUCT TO WHICH THIS LIMITED WARRANTY APPLIES IS A "CONSUMER PRODUCT" UNDER THE MAGNUSON-MOSS WARRANTY ACT (15 U.S.C.A. §2301, ET SEQ.) OR OTHER APPLICABLE LAW, THE FOREGOING DISCLAIMER OF IMPLIED WARRANTIES SHALL NOT APPLY TO YOU, AND ALL IMPLIED WARRANTIES ON THIS PRODUCT, INCLUDING WARRANTIES OF MERCHANTABILITY AND FITNESS FOR THE PARTICULAR PURPOSE, SHALL APPLY AS PROVIDED UNDER APPLICABLE LAW.

Other Conditions

This limited warranty gives you specific legal rights, and you may have other rights which vary from country to country or state to state.

This limited warranty is void if (i) the label bearing the serial number of this product has been removed or defaced, (ii) the product is not distributed by Kramer Electronics or (iii) this product is not purchased from an authorized Kramer Electronics reseller. If you are unsure whether a reseller is an authorized Kramer Electronics reseller, visit our web site at www.kramerav.com or contact a Kramer Electronics office from the list at the end of this document.

Your rights under this limited warranty are not diminished if you do not complete and return the product registration form or complete and submit the online product registration form. Kramer Electronics thanks you for purchasing a Kramer Electronics product. We hope it will give you years of satisfaction.



P/N: 2900-301785



Rev: 2



SAFETY WARNING

Disconnect the unit from the power supply before opening and servicing

For the latest information on our products and a list of Kramer distributors, visit our website where updates to this user manual may be found.

We welcome your questions, comments, and feedback.

The terms HDMI, HDMI High-Definition Multimedia Interface, and the HDMI Logo are trademarks or registered trademarks of HDMI Licensing Administrator, Inc. All brand names, product names, and trademarks are the property of their respective owners.